

xtremeDBmini[®]: J1939 CANBUS

User Manual



Table of Contents

Document Revision History	3
Description of Manual and Product	3
Safety Information	4
Part Number Structure	5
Module Overview	6
Technical Data.....	6
Installation and Maintenance Notes.....	7
J1939 LEDs.....	8
Fault Diagnostics.....	9
Powering the Module.....	10
I/O Specifications	13
Variant-Specific Information.....	13
Module Pinouts.....	14
Parallel Output Pinouts.....	14
H-Bridge Output Pinouts.....	14
Input Operation.....	15
Counter Operation.....	16
Encoder Operation.....	17
Output Operation.....	18
PWM(i) Operation.....	18
Status Messages.....	18
J1939 Configuration	19
Configuration Process.....	19
Configuration Notes.....	21
SA and Baud Rate Configuration with Magnet Switch.....	22
Command Message Details.....	23
PGNs Used.....	31
PGN Message Details.....	32
Programming/Firmware Notes	39
Accepted Accessories	39
Warranty and Liability Claims	40
Message Location Within This Document	41
Glossary	42
Mode Operation Examples	43

Document Revision History

- A Initial release, March 2022
- B Updated with minor edits, June 2023
- C Updated for *xtremeDBm-1*® COMBO release, August 2024 (01.9A)

Description of Manual

This user manual is a resource to users for correct maintenance and operation of this product. The text, illustrations, diagrams, and examples used in this manual exist solely for the purpose of explaining the operation and usage of *xtremeDBm*®: *DP-40044-01*, *DP-40044-02*, *DP-40044-05* modules. If you have any further questions regarding the installation and set-up of the equipment described in this manual, please do not hesitate to contact us at dptech@murrinc.com. Data Panel Corporation and Murrelektronik reserve the right to make changes or modifications to this manual without prior notice.

Description of Product

xtremeDBm® is the ultimate mobile solution for both on-highway and off-highway system applications with I/O signal and power distribution needs of up to 26 Amps. This family of distribution blocks takes advantage of DEUTSCH connections to achieve IP67/IP69K ratings, and pin-level LED diagnostics make for improved field serviceability. In addition to short circuit and overcurrent protection, a complete set of fault codes is shown via port- and module-level LED's, and these codes that are broadcasted on the network can enable fault messages on the display so operators can quickly identify possible problems on the machine. With these blocks installed in your vehicles, spiderweb harnesses will be eliminated to significantly reduce your wiring efforts, and your cable runs to each device will be considerably shorter.

The trademark DEUTSCH is owned by the TE Connectivity Ltd. family of companies.

Applicable Data Sheets:

DP-40044-01-000_db_e
 DP-40044-02-000_db_e
 DP-40044-05-000_db_e

Applicable Installation Manuals:

DP-40044-01-000_ina_10
 DP-40044-02-000_ina_10
 DP-40044-05-000_ina_10

Applicable Software Quickstart Guides

Block Tool
 DPLoader
 DPNPlayer

Safety Information

TARGET GROUPS

This manual addresses itself exclusively to qualified and trained technicians knowledgeable in the safety standards of automation technology. Only a qualified, trained technician knowledgeable in the safety standards of the mobile industry may perform configuration, installation, set-up, maintenance, and testing of the equipment.

DESIGNATED USE

The input/output modules of the xtremeDB® series are designated for use only in those areas as described in this manual. Strict adherence to the data specified in this manual and other published documentation must be ensured. The products have been developed, manufactured, tested, and documented in compliance with safety codes noted in the data sheets. The equipment poses no danger to operating personnel or material if configuration, assembly, and operation are performed in compliance with the stated handling and safety regulations. Unqualified intervention in the hardware and software of our equipment, disregard of warning labels found on the equipment, or non-observance of the information in this manual can result in injury or serious damage to man and/or material. Any application or usage beyond and above this shall be regarded as non-designated.

REGULATIONS

Current safety and accident prevention laws valid for a specific application must be observed in the configuration, installation, setup, and maintenance and testing of the equipment.

1. The designated function of the module is guaranteed only if the conditions for installation, system extension, operation, and maintenance are complied with and the housing is fully installed. Any modifications to the housing are not allowed.
 - i. The module described is installed as a subcomponent in a system. The safety of this system is the responsibility of the creator. The system manufacturer is obliged to carry out a risk assessment, and from this to prepare and enclose documentation in accordance with the legal and normative requirements for the operator and the user of the system. This must contain all necessary information and safety instructions for the operator, user and, if applicable, service personnel authorized by the system manufacturer.
 - ii. Read this document before putting the product into operation; keep this document for the duration of product use.
2. Only system accessories and cables that meet the requirements and regulations for safety, electromagnetic compatibility and, where applicable, telecommunications transmission equipment and specifications are allowed. The installation of other accessories may violate these requirements and regulations or damage the equipment. Information concerning the type of authorized system extensions and cables can be obtained from your Murrelektronik distributor or taken from this manual.
3. Welding may damage the integrity of the module. Use good welding practices.
 - i. Damage or impairment of electrical safety may occur due to overcurrent, welding spatter, and contamination from welding work.
 - ii. Welding work on the chassis frame may only be carried out by qualified personnel.
 - iii. Remove and cover the positive and negative terminals of the batteries.
 - iv. Disconnect the module with all contacts from the onboard power supply before welding on the vehicle or on the system.
 - v. Connect the ground clamp of the welding device directly to the part to be welded.
 - vi. Do not touch the module and electrical lines with the welding electrode or the ground terminal of the welding device.
 - vii. Protect the module, including all connection plugs and all connection lines, against welding spatter and other contaminants.
4. This product is designed and manufactured to assure protection against damage and hazards if designated usage and proper maintenance are observed.
 - i. This product must be suitable without restriction for the applications and environmental conditions concerned. **This product is not a safety component or appropriate for potentially explosive environments.** Only use the product as intended. Failure to observe application instructions or technical specifications may result in damage to property and/or personal injury.

END USER LICENSE

EXCLUSION OF INCIDENTAL, CONSEQUENTIAL, AND CERTAIN OTHER DAMAGES:

To the maximum extent permitted by applicable law, in no event shall Data Panel or Murrelektronik be liable for any special, incidental, indirect, or consequential damages whatsoever (including, but not limited to, damages for loss of profits or confidential or other information, for business interruption, for personal injury, for loss of privacy, for failure to meet any duty including of good faith or of reasonable care, for negligence, and for any other pecuniary or other loss whatsoever) arising out of or in any way related to the use of or inability to use the software product, the provision of or failure to provide support services, or otherwise under or in connection with any provision of this End User License, even in the event of the fault, tort (including negligence), strict liability, breach of contract or breach of warranty of Data Panel or Murrelektronik, or any supplier, and even if Data Panel or Murrelektronik or any supplier has been advised of the possibility of such damages.

EXAMPLE OF SYMBOLS

Use of Attention Signs

Notes containing important information are specially marked. These are illustrated as follows:



Attention text...

Use of Danger Signs

Danger signs are indicated by text and a corresponding symbol inside of a frame:



CAUTION!

Disregard for safety measures may result in damage to equipment and other serious consequences.

Part Number Structure

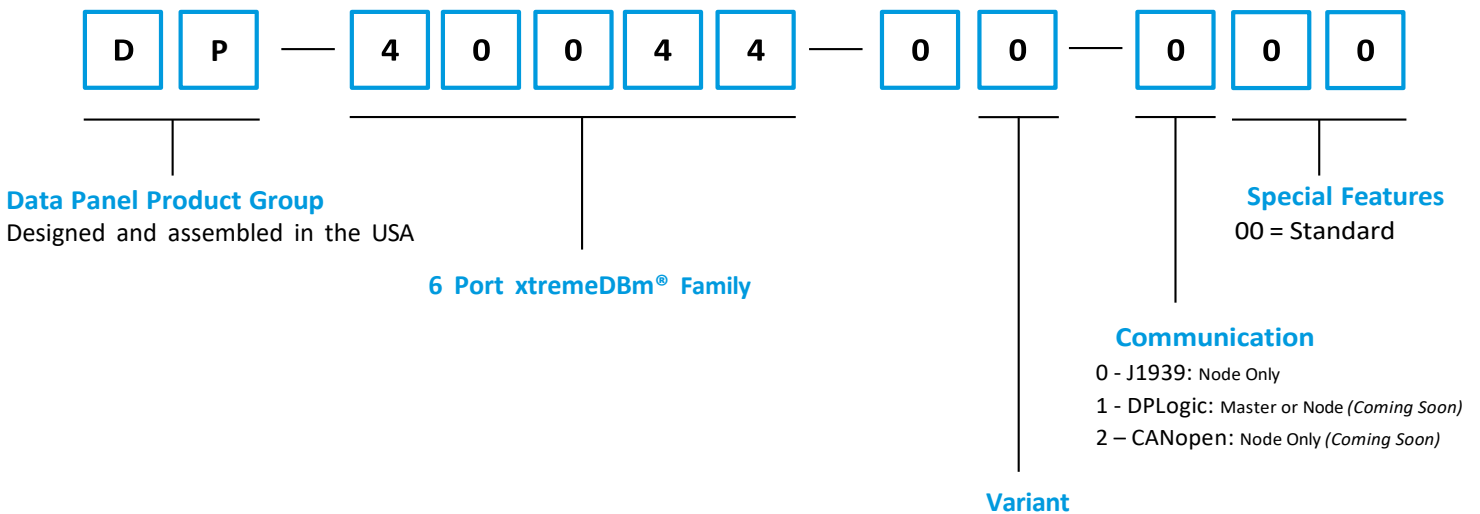

- 00 - CAN Splitter (not included in this manual)
- 01 - Combo Block: 4 Inputs/4 Outputs (includes all input/output types)
- 02 - All Inputs
- 05 - All Outputs: Digital

Example: **DP-40044-01-000** is a xtremeDBm® J1939 I/O Combo block.

First generation part numbers will be updated by adding "-000" to indicate standard J1939 modules.

Module Overview

TECHNICAL DATA

LEDs for visual diagnostics at the ports

Module power and CAN communication

DEUTSCH connectivity for sensors, valves and other components

IP69K with Murrelektronik MDC cables



AT A GLANCE

- Configurable Inputs and Outputs
 - Inputs: Digital, 0-5V DC, 0-10V DC, 4-20 mA, counter, frequency, encoder, ratiometric, ground input
 - Outputs: Digital, PWM, PWM(i)
- Two I/O Pins per Port, 8 Total Inputs/Outputs
- Current Rating
 - Up to 26A per module
 - Up to 5A per output
- Works in 12 and 24V DC systems
- Output Port Paralleling Supported up to 8A*
- H-Bridge Port Configuration Capability*
- Configurable Sensor Power (VBAT or 5V DC)*
- Operating Temperature Range: -40 to 85°C
- Size: 9.4" (L) x 2" (W) x 0.7" (D)
- Optimized Applications and Firmware

*Available only on the DP-40044-01-000 variant. See pages 13-14 for technical details specific to each variant.

Installation	(2) M5 x 1 screws
Communication	2 non-isolated J1939 ports (250kb & 500kb)
Voltage Range	8-32V DC
Current Draw	<100mA
Operating Temperature	(-40 to 85°C)
Storage Temperature	(-40 to 85°C)
Protection	IP69K with Murrelektronik MDC cables
Number of Ports	4
Total Number of I/O	8
Sensor Power Diagnostics	Short Circuit and Overcurrent
Output Diagnostics	Short Circuit and Overcurrent
Analog Resolution	12 bit, 1% Full Scale Accuracy

INSTALLATION AND MAINTENANCE NOTES

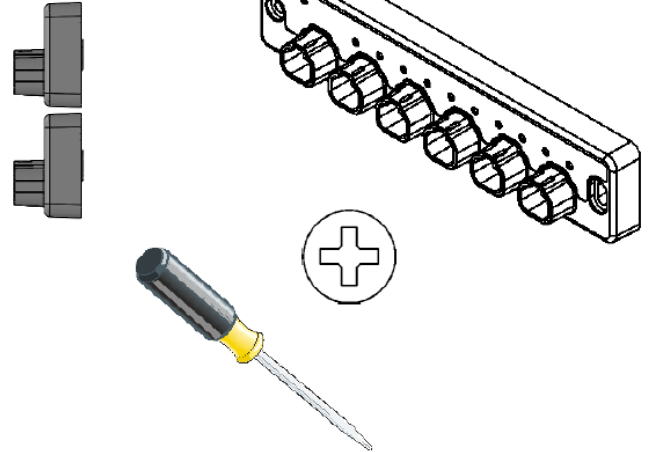
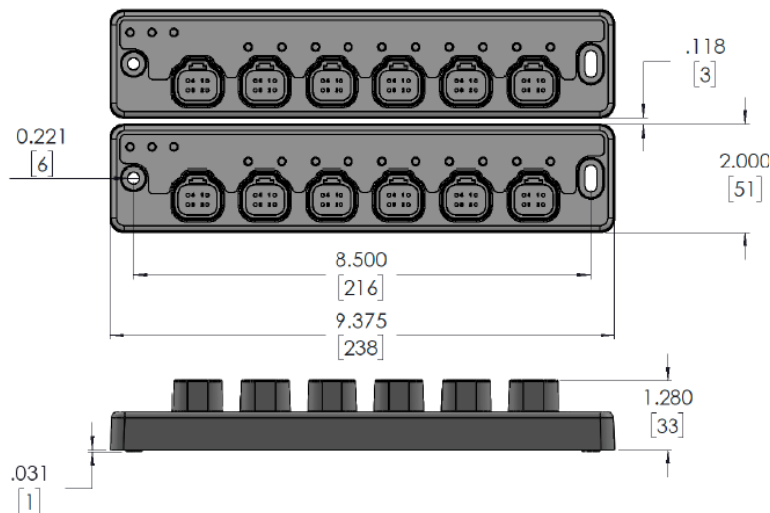

Installation

The xtremeDBm® blocks can be mounted directly on an installation panel or on a machine. The module features two mounting holes, which each accept M5 screws, for this purpose. The mounting surface must be smooth and flat to prevent mechanical stress in the module housing. Prevent torsional forces or mechanical loads from acting on the housing.

- Power connections should be fused externally to the block.
- The module must not exceed or fall below the specified tolerances.
- Select and install connecting cables in such a way that capacitive and inductive interference does not impair the system.
- Avoid contamination before and during installation until the protection rating is ensured by plugs or dummy plugs.
- Secure the module against misuse and accidental use.

See Safety Information for detailed notes on safe application of this product.

Servicing and Cleaning

The module itself is maintenance-free. No inspection and maintenance work is necessary during operation. However, a regular check of your overall system should be included in the maintenance schedule of your machine in order to detect possible defects caused by external influences at an early stage.

- **Clean soiled contacts only with oil-free compressed air or with alcohol and a lint-free cloth. Do not use contact spray.**
- **When using aggressive mediums near the block, check the application-specific material resistance. This product has good chemical and oil resistance; refer to data sheet for material specifications.**



All unused ports should be plugged. All unused pins should be plugged with a DEUTSCH #114017 sealing plug to maintain the IP69k rating.

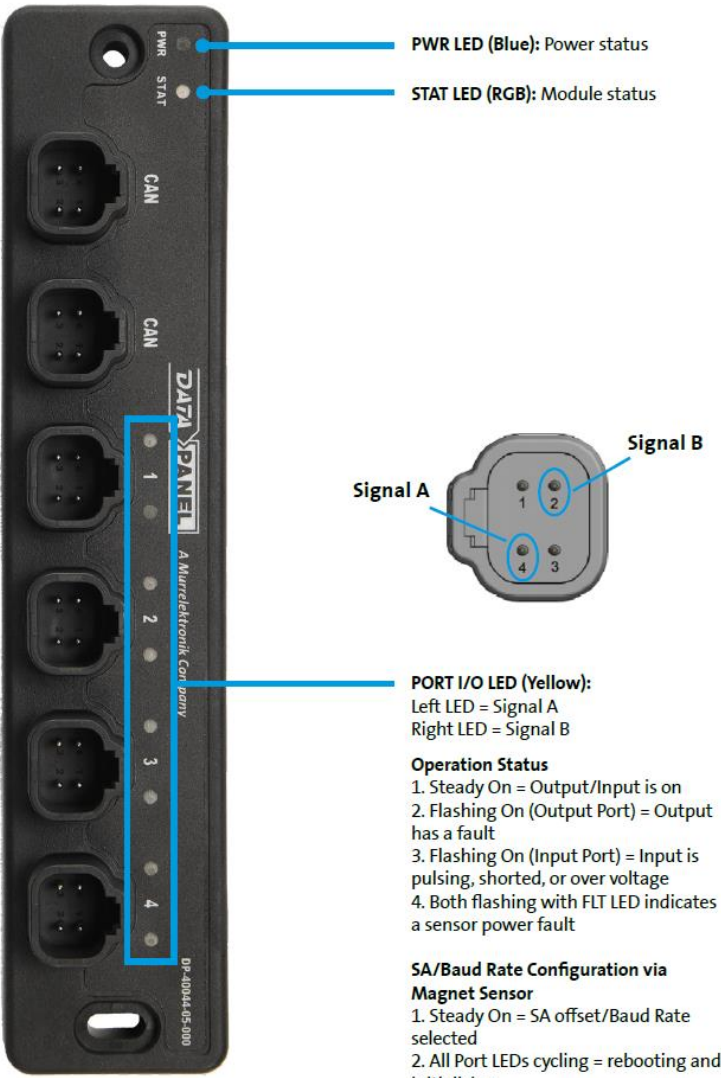

PWR LED (Blue): Power status
STAT LED (RGB): Module status

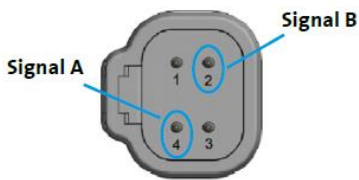

PORT I/O LED (Yellow):
 Left LED = Signal A
 Right LED = Signal B

Operation Status

1. Steady On = Output/Input is on
2. Flashing On (Output Port) = Output has a fault
3. Flashing On (Input Port) = Input is pulsing, shorted, or over voltage
4. Both flashing with FLT LED indicates a sensor power fault

SA/Baud Rate Configuration via Magnet Sensor

1. Steady On = SA offset/Baud Rate selected
2. All Port LEDs cycling = rebooting and initializing

STAT LED (RGB - Cyan): Magnet Switch Configuration

Fault Description	ON	OFF
Magnet Switch ON, Configuration Saving	ON	N/A

STAT LED (RGB - White): Magnet Switch Configuration

Fault Description	ON	OFF
Magnet Switch ON, Configuration Saved	ON	N/A

J1939 LED INDICATION

During start up, all LEDs will turn on for 3-5 seconds to verify that they are working (bulb test).

Short = ON 500ms and OFF 500ms
 Long = OFF defined as 2.0 s

PWR LED (Blue): Power Status

ID	Code	Fault Description	ON	OFF
P0	N/A	Module ON, Valid Voltage Ranges	ON	N/A
P1	21	Low Voltage Warning	1 Short	1 Long
P2	22	Over Voltage Warning	2 Short	

STAT LED (RGB - Pink): DPLoGic, Magnet Switch Status

ID	Fault Description	ON	OFF
N/A	DPLoGic Running, No Faults Detected	ON	N/A
N/A	CAN Communication Detected During Active Configuration Function	1 Short	1 Short
N/A	Module in SA/Baud Rate Configuration State	ON	N/A

STAT LED (RGB - Green): Communication Status

ID	Fault Description	ON	OFF
G0	Valid Communication Network	ON	N/A
G1	Bootload Mode*	1 Short	1 Long

STAT LED (RGB - Blue): Power Condition Status (Precedence: 1)

ID	Code	Fault Description	ON	OFF
B1	41	Low Voltage Hold	1 Short	1 Long

STAT LED (RGB - Red): Module Status (Precedence: 2)

ID	Code	Fault Description	ON	OFF
R0	N/A	Bootload Mode*	1 Short	1 Short
R1	51	Output Overcurrent (F1) Fault	1 Short	1 Long
R2	52	Output Short Circuit (F2) Fault	2 Short	
R3	53	Input Over Voltage (F3) Fault	3 Short	
R7	N/A	Node (F7) Faults	7 Short	

STAT LED (RGB - Yellow): Module Status (Precedence: 3)

ID	Code	Fault Description	ON	OFF
Y0	N/A	Voltage Warning	ON	N/A
Y1	31	Source Address (SA) Arbitration Fail	1 Short	1 Long
Y2	32	CANBUS Network Fault	2 Short	
Y3	33	Output Control Message Missing	3 Short	
Y4	34	Over Temperature (F4) Warning	4 Short	

* STAT LED will alternate between red and green while in Bootload Mode, indicating CANBUS traffic



The module may be online before the end of the bulb test; I/O may be active during the bulb test.

FAULT DIAGNOSTICS

- When multiple faults are present, shown faults via the LEDs are prioritized. See pg. 8 for order of precedence.
- Resetting an output fault will require cycling the module power unless the Controller Mode Output Reset is enabled. If the Controller Mode Output Reset is enabled, the fault will be reset when the output is turned off, limited to 5 times before a module power cycle will be required. An output fault will not affect the other outputs on the module.
- Over voltage is defined as an input voltage > 32V DC.
- Low voltage is defined as an input voltage < 10V DC.

Fault Description	Fault Indication	Possible Failure Conditions	Suggested Solutions
Low Voltage Warning	1 short, 1 long on PWR LED	POWER voltage is less than 11.0 V DC for 8s	Extended operation below the low voltage threshold WILL NOT damage the module. Low voltage indicates the condition of the system.
Over Voltage Warning	2 short, 1 long on PWR LED	POWER voltage is greater than 32 V DC for 8s	Extended operation above the high voltage threshold MAY CAUSE PERMENANT DAMAGE to the module. Reduce system voltage.
Over Temperature Warning	4 short, 1 long Yellow on STAT LED	TEMP reading is greater than 80°C for 8s	Additional module cooling may be required for the application to avoid failure due to extended operation outside of the specified temperature range.
Input Over Voltage	3 short, 1 long Red on STAT LED	Incorrect voltage range may have been selected for an analog input or Battery voltage may be exceeding the maximum rating for the device	When an analog input over voltage has been detected, the module will adjust the selected analog input voltage range to protect itself from damage. Momentary voltage spikes above the specified voltage range of the device MAY CAUSE PERMENANT DAMAGE .
Internal Module Failure	7 short, 1 long Red on the STAT LED	Internal hardware failure	Cycle power.
Bootload Mode	1 short, 1 short Green and Red on STAT LED	Under normal operation, the COM and FLT LEDs will flash the bootload pattern during the bootload process. Bootload mode will persist until the bootload cycle has fully completed. I/O will not be functional until the device has exited bootload mode.	If CAN communication or power was removed from the device during bootload, power cycle the device and restart the bootload process. Ensure the proper firmware is being loaded for your device version. Attempting to load a DP-40044-01-000 with DP-40044-01-0100 firmware will lock the device in bootload mode until the appropriate DP-40044-01-000 firmware has been reloaded into device.
Source Address Arbitration	1 short, 1 long Yellow on STAT LED	The device has detected an identical source address already on the CANBUS	Check that P0 has the appropriate jumpers with good connections. Ensure a power cycle was performed after any address changes were applied. Source addresses must be unique on each CANBUS.
CANBUS Hardware Fault	2 short, 1 long on COM LED	Open CANBUS with either CANH or CANL, or both, not connected	Ensure CANH and CANL are connected to the correct pins on both ends of the harness. Ensure the BUS is properly terminated with 120 Ohm resistors according to the J1939 standard. Check terminating resistors and CANH, CANL connections.
Output Control Message Missing	3 short, 1 long Yellow on STAT LED	The block is not receiving Command 0x51h	Message 0x51h must be received every 200mS or this fault will continue to occur.
Output Overcurrent	1 short, 1 long Red on STAT LED	An output is requesting more than the specified current limit of the output	Inspect wiring harness for damage. Inspect for seized loads, ect.
Short Circuit	2 short, 1 long Red on STAT LED	An output short circuit has been detected	Inspect wiring harness for damage. Inspect for seized loads, ect.

DP-40044-01-XXX I/O Diagram

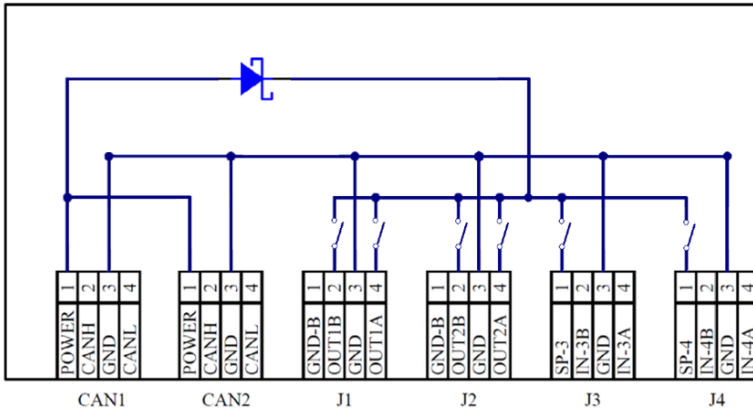

POWERING THE MODULE: DP-40044-01

The module receives its power from the CAN ports. Module power is limited to 16 amps and is used to power output ports, input sensor ports and connected modules down the line.

Power	CAN
Pin 1 = POWER	Pin 2 = CAN High
Pin 3 = GROUND	Pin 4 = CAN Low

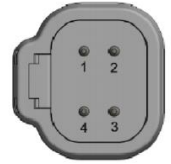

Module Power (POWER)

This circuit has power and ground supplied by the CAN port.

Sensor Power

Each Input port has sensor power which can be configured for either source voltage (VBAT) or 5V DC. The module monitors Port Sensor Power current and shuts off the sensor power in a port if the maximum current exceeds 1A for VBAT or at 200mA for 5V DC.

Both short circuit and overcurrent protection is provided.

POWERING THE OUTPUTS

BUS Power

The device monitors module input current and will shut off all applicable outputs if the maximum current exceeds 13 amps per power pin feed. To increase the maximum current capability of the module to 16 amps, power feeds should be supplied through both CAN ports.



Input and Output Ports

CAN Ports: Non-Isolated



The connection between CAN1 & CAN2 for the power feed is not fused (protected from short circuit current). During installation, the module power wiring on CAN1 & CAN2 pin 1 should have a 13A fuse before the modules.



CAN ports should NOT be used to power any output devices.

DP-40044-02-XXX I/O Diagram

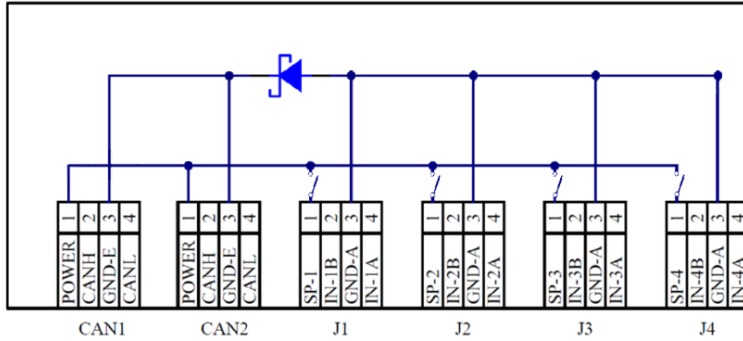

POWERING THE MODULE: DP-40044-02

The module receives its power from the CAN ports. Module power is limited to 13 amps and is used to power both input ports and connected modules down the line.

Power
Pin 1 = POWER
Pin 3 = GROUND

CAN
Pin 2 = CAN High
Pin 4 = CAN Low

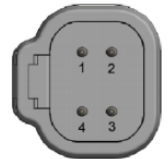

Module Power (POWER)

This circuit has power and ground supplied by the CAN port.

Sensor Power

The module monitors Port Sensor Power current and shuts off the sensor power in a port if the maximum current exceeds 1 amps per port. Both short circuit and overcurrent protection is provided.

Port 1- Port 4 = Power, 1 amps each

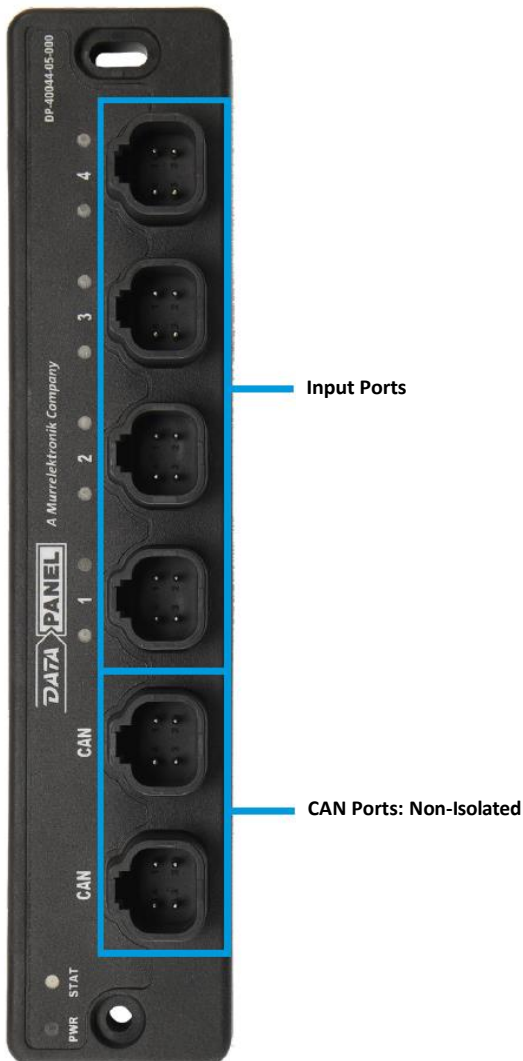

Module and sensor power is provided via the CAN port.



The connection between CAN1 & CAN2 for the power feed is not fused (protected from short circuit current). During installation, the module power wiring on CAN1 & CAN2 pin 1 should have a 13A fuse before the modules.



CAN ports should NOT be used to power any output devices.

DP-40044-05-XXX I/O Diagram

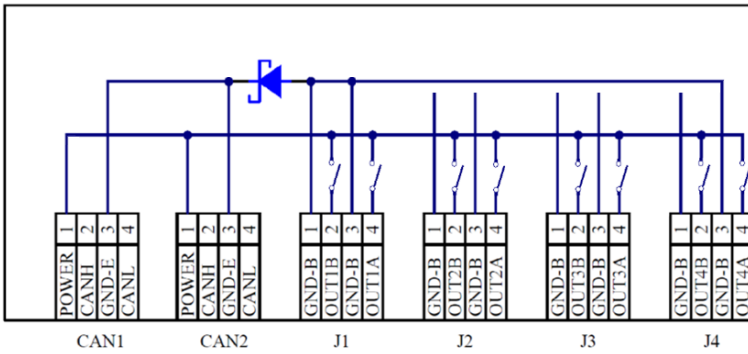

POWERING THE MODULE: 40044-05

The module receives its power from the CAN ports. Module power is limited to 26 amps and is used to power output ports and connected modules down the line.

- Power**
Pin 1 = POWER
Pin 3 = GROUND
- CAN**
Pin 2 = CAN High
Pin 4 = CAN Low

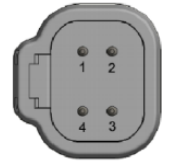

Module Power

This circuit has power and ground supplied by the CAN port.

POWERING THE OUTPUTS

BUS Power

The device monitors module input current and will shut off all applicable outputs if the maximum current exceeds 13 amps per power pin feed. Both CAN ports can be used to double to 26 amps. Short circuit protection is provided.

All eight Ground B pins are connected internally. Each module input power pin allows for an additional 13 amps of output power.



The connection between CAN1 & CAN2 for the power feed is not fused (protected from short circuit current). During installation, the module power wiring on CAN1 & CAN2 pin 1 should have a 13A fuse before the modules.



Module power should NOT be used to power any output devices.

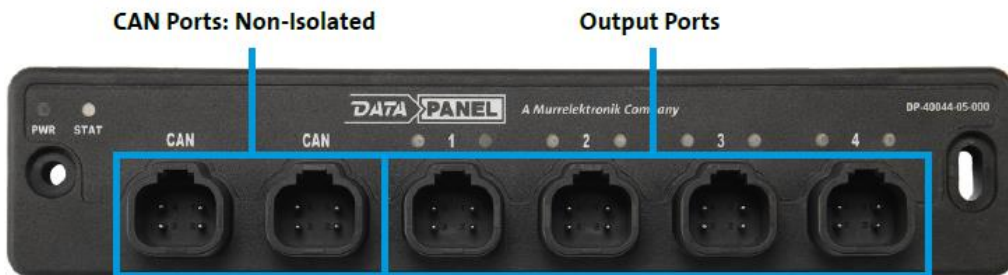

I/O Specifications

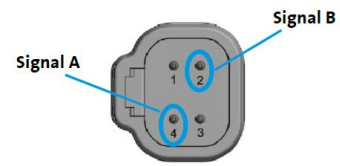

DP-40044-01: Combo Block		
Total Number of I/O	8 (4 inputs, 4 outputs)	
Configurable Inputs	4 Digital or Analog	
Digital Input Configurations	Digital Positive, Digital Ground, Frequency/Counter/Encoder	
Analog Input Configurations	0-5V DC, 0-10V DC, 0-32V DC, 4-20mA, Ratiometric	
Configurable Outputs	4 Digital, PWM, or PWM(i)	
Total Output Current	16A	
Digital Inputs Port 3: A, B Port 4: A, B	<u>Positive switching</u> Input A threshold Input B threshold Input Resistance	>1.6 V DC >1.6 V DC 10 kΩ
Default Configuration <i>Positive Switching</i>	<u>Ground switching</u> Input A threshold Input B threshold Input Resistance	<1.6 V DC <1.6 V DC 10 kΩ
	Input Response	20 mSec
Analog Inputs Port 3: A, B Port 4: A, B	<u>Voltage Input</u> Voltage Range	0...5 V DC 0...10 V DC 0...32 V DC
	Resolution	12 bit
	Input Resistance	5 V DC 166 kΩ 10 V DC 55 kΩ 32 V DC 37.6 kΩ
	Accuracy	1% Full Scale
	Input Response Time	20 mSec
	<u>Current Input</u> Current Range Resolution Input Resistance Accuracy Input Response Time	0-25 mAmp 12 bit 162 Ω 1% Full Scale 20 mSec
	<u>Ratiometric Input</u> Voltage Range Resolution Input Resistance Input Response Time	0...32 V DC 0.1% (0-100.0%) 37.6 kΩ 20 mSec
Outputs Port 1: A, B Port 2: A, B	<u>Digital Output</u> Output Voltage	8...32 V DC
	Switching Current	4 Amps
Default Configuration <i>Digital 4 Amps</i>	<u>Current-Controlled Output</u> PWM Frequency PWM(i) Frequency Switching Current	40-1100 Hz 100-700 Hz 4 Amps

DP-40044-02: Input Block		
Total Number of I/O	8 (all inputs)	
Digital Input Configurations	8 Digital Positive, Digital Ground, or Frequency/Counter/Encoder	
Analog Input Configurations	0-5V DC, 0-10V DC, 0-32V DC, 4-20mA, Digital Ground, Digital Positive, Ratiometric	
Total Input Current	13A	
Digital Inputs Port 1: A, B Port 2: A, B Port 3: A, B Port 4: A, B	Input A Switching Input B Switching Input Resistance	>1.6 V DC >4.0 V DC Positive 10 kΩ Ground 470 kΩ
	Input Response Time	20 mSec
Default Configuration <i>Positive Switching</i>	<u>Counter/Encoder: 3A, 4A</u> Positive Switching Frequency	>1.6 V DC 0 – 5000 Hz
Analog Inputs Port 1: B Port 2: B Port 3: B Port 4: B	<u>Voltage Input</u> Voltage Range	0...5 V DC 0...10 V DC 0...32 V DC
	Resolution	12 bit
	Input Resistance	5 V DC 166 kΩ 10 V DC 55 kΩ 32 V DC 37.6 kΩ
	Accuracy	1% Full Scale
	Input Response Time	20 mSec
	<u>Current Input</u> Current Range Resolution Input Resistance Accuracy Input Response Time	0-25 mAmp 12 bit 162 Ω 1% Full Scale 20 mSec
	<u>Ratiometric Input</u> Voltage Range Resolution Input Resistance Input Response Time	0...32 V DC 0.1% (0-100.0%) 32 V DC 37.6 kΩ 20 mSec

DP-40044-05: Digital Output Block		
Total Number of I/O	8	
Output Configurations	8 Digital	
Switching Current	8 Outputs: 5A	
Total Output Current	26A	
Outputs Port 1: A, B Port 2: A, B Port 3: A, B Port 4: A, B	Digital Output Output Voltage Switching Current	8...32 V DC 5 Amps



Each Load must use the return Ground (B) pin.
"Chassis Grounding" is not recommended.

MODULE PINOUTS

CAN Port



I/O Port



CAN port GND-EXT connections are internally connected.



A Ground (B) connection must be made for every 13A consumed by the block.

DP-40044-01: Combo Block

Pin	CAN Ports 1 & 2
1	POWER
2	CAN HIGH
3	GROUND
4	CAN LOW
Output Ports 1-2	
1	GROUND
2	OUTPUT B (4 Amps)
3	GROUND
4	OUTPUT A (4 Amps)
Input Ports 3-4	
1	SENSOR POWER
2	INPUT B
3	GROUND
4	INPUT A

DP-40044-02: Input Block

Pin	CAN Ports 1 & 2
1	POWER
2	CAN HIGH
3	GND-EXT
4	CAN LOW
Input Ports 1-4	
1	SENSOR POWER
2	INPUT B
3	GROUND A
4	INPUT A

DP-40044-05: Digital Output Block

Pin	CAN Ports 1 & 2
1	POWER
2	CAN HIGH
3	GND-EXT
4	CAN LOW
Output Ports 1-4	
1	GROUND B
2	OUTPUT B (5 Amps)
3	GROUND B
4	OUTPUT A (5 Amps)

PARALLEL OUTPUT PINOUTS (DP-40044-1-000)

The output ports on the xtremeDBm[®]-1 COMBO block can be configured to 'Parallel Mode', where Signal A and Signal B can be spliced together to form a higher amperage output of up to 8 Amps.

To configure the port to 'Parallel Mode' refer to Command 0x5Dh on [Page 30](#).

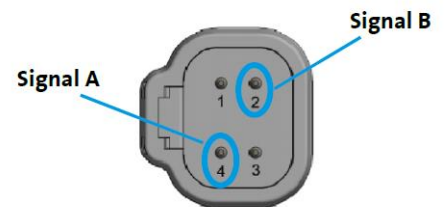

H-BRIDGE OUTPUT PINOUTS (DP-40044-1-000)

The output ports on the xtremeDBm[®]-1 COMBO block can be configured to 'H-Bridge Mode', where Signal A and Signal B can be used to run a directional load of up to 4 Amps forward or in reverse.

To configure the port to 'H-Bridge Mode' refer to Command 0x5Dh on [Page 30](#).

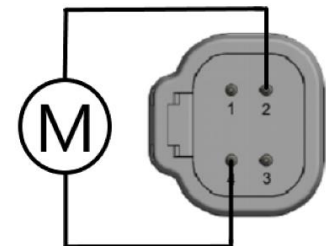

During Paralleling and H-Bridge operations, loads should be limited to the two output pins within the same port. DO NOT wire your output devices across two different ports.

INPUT OPERATION

The input operation will be different depending on the configuration chosen for the input and the input pin being configured. See CAN tables for specific bit assignment. **Sensor power for each port can be configured and enabled to receive 8-32VDC (VBAT) or 5VDC on Pin 1. See [Command 0x5Ch](#) to configure and [Command 0x51h](#) to enable sensor power.**

Input Operation				
Function	DP-40044-01 Applicable Ports	DP-40044-02 Applicable Ports	Mode Value	Description
Disabled	A & B	A & B	0	Putting a "0" in the mode for an input disables the input. It is recommended to disable any inputs that aren't being used.
Digital Positive On/Off	A & B	A & B	1	This puts the input into the standard digital positive operation mode. When a positive voltage is present on the input pin, the low bit will turn on.
Digital Ground On/Off	A & B	A & B	2	This puts the input into the standard digital ground operation mode. When a ground is present on the input pin, the low bit will turn on.
4-20 mA	A & B	B	3	This puts the input into 4-20 mA mode with a value of 4,000 - 20,000 = 4000 - 20,000 macro amps. See Table 1 in the Mode Operation Examples.
0...5 V DC	A & B	B	4	This puts the input into 0...5 V DC mode with a value of 0 - 5,000 = 0 - 5,000 mV. See Table 2 in the Mode Operation Examples.
0...10 V DC	A & B	B	5	This puts the input into 0...10 V DC mode with a value of 0 - 10,000 = 0 - 10,000mV. See Table 3 in the Mode Operation Examples.
0...32 V DC	A & B	B	6	This puts the input into 0...32 V DC mode with a value of 0 - 32,000 = 0 - 32,000 mV. See Table 4 in the Mode Operation Examples.
Frequency	A & B	A	7	This puts the input into frequency operation mode. When a positive signal is present on the input pin, the frequency will be shown. Only valid on Ports 3 and 4 for DP-40044-01, -02.
Counter	A & B	A	8	This puts the input into counter operation mode. When a positive signal is present on the input pin, the count will increase. Only valid on Ports 3 and 4 for DP-40044-01, -02.
Ratiometric	A & B	B	9	This puts the input into Ratiometric mode with a value of 0 - 1,000 equaling 0 - 100.0% of P0 Battery voltage. See Table 5 in the Mode Operation Examples.
Encoder	A & B	A	A	This puts the 2 inputs into Encoder operation mode. For example, on the -02, both input 3A and 4A are used for the encoder input; when changing input 3A to encoder mode, it automatically sets up 4A to work with it. See Encoder Operation on page 17. Only valid on Ports 3 and 4 for DP-40044-01, -02.



The DP-40044-01 requires sensor power to be activated for *Digital Ground ON/OFF* Input operations.

Input Status Messages		
Function	Applicable Variants	Description
Digital Input Message (DIGIN)	DP-40044-01, -02	2 bit "bit pairs" for digital inputs
Analog Inputs 1A-2B Message (AD2)		16 bit decimal data for analog readings
Analog Inputs 3A-4B Message (AD3)		
Frequency Inputs Messages (FREQ1 & FREQ2)		Counter, Frequency, Encoder Inputs

Counter Operation

xtremeDBm® has a counter function, which allows for the control of designated outputs to work asynchronously to the controller. The output, if the enable bit is on and upon reaching its setpoint, will shut off. The output will not automatically turn on when the counter is on. The counter can be set up using configuration 0x57h. Counter data, in the form of 16-bit unsigned numbers (0-65535), is stored in Message [FREQ1 & FREQ2].

Counter: Basic

Setpoint zero, Reset off, Overflow off

Turning off the counter does not reset the accumulative value of the counter. If Overflow is not selected, the counter will only accrue up to the setpoint entered or **65535**. Subsequent counts are ignored.

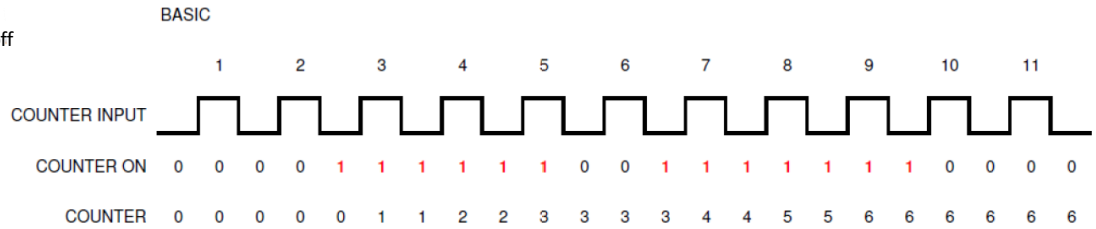

Counter: Using Reset

Setpoint zero, Overflow off

A counter reset does not clear the counter setpoint. A counter reset will clear the current count and does not turn the counter OFF.

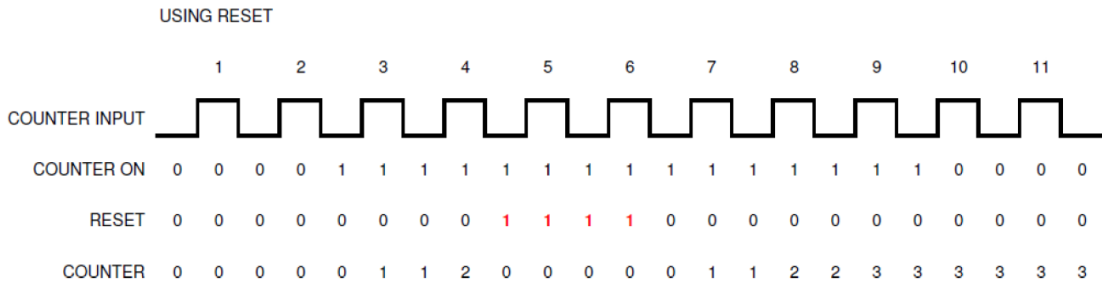

Counter: Using Setpoint

Setpoint set, Reset off, Overflow off

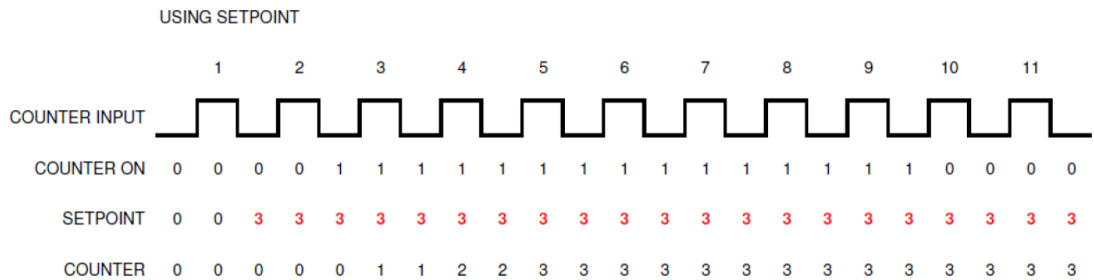

Counter: Linking Output and Overflow

Setpoint set, Reset off, Overflow on, Output Enable on

Output 1A Enable can be linked to Counter 3A. Output 2A Enable can be linked to Counter 4A. The output must be turned on by the controller in the digital control message, then the counter is turned on. The output is turned off when the setpoint is reached. A counter reset is required for the next cycle.

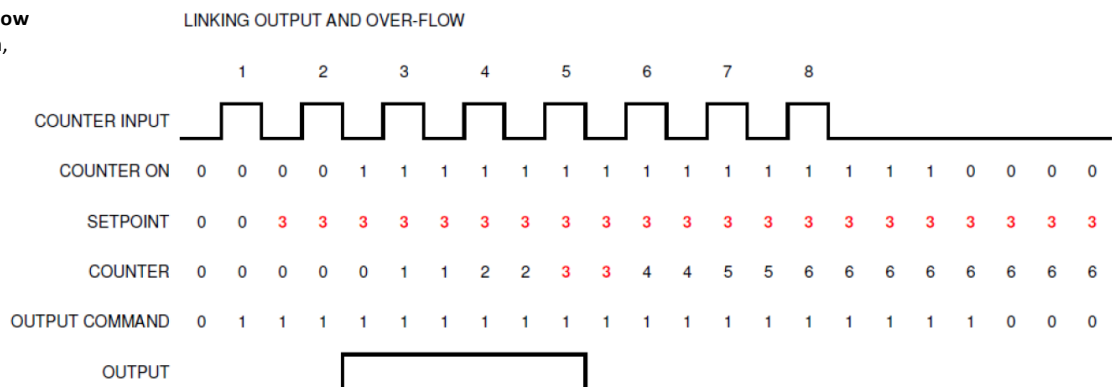

Encoder Operation

xtremeDBm® has an encoder function that, when the channels are correctly connected, takes care of incrementing or decrementing the count. In encoder mode, bytes 1 & 2 are the low word and bytes 3 & 4 are the high word to display a 32 bit value of the encoder count. The 32 bit signed maximum positive count is **2,147,483,647**. For the 40044-02, this mode is accessible via input ports 3A and 4A, and any compatible functions are tied to counter 3A: ON/OFF or Reset. Channel A of the encoder is connected to Input 3A and Channel B is connected to Input 4A.

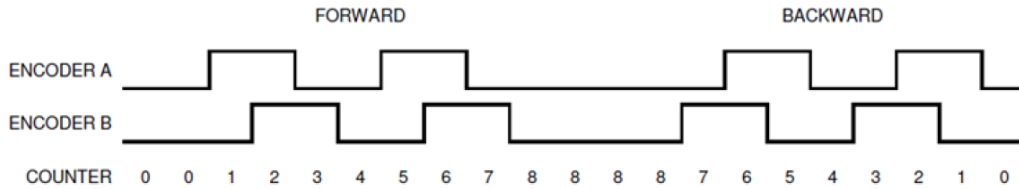

Encoder setup uses Command 0x57h. When port 3A is configured as an Encoder, Port 4A configuration is ignored. Encoder data is in Message [FREQ] PGN 65307. The xtremeDBm® encoder function, when the channels are correctly connected, takes care of incrementing or decrementing the count.

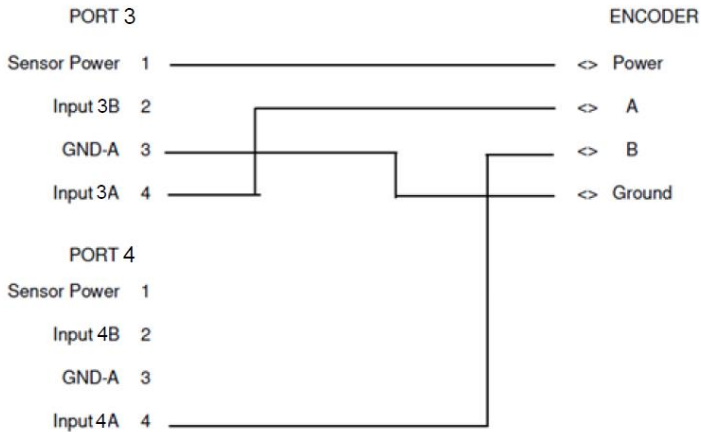

Encoder Configuration									
Data Type		Bit 7	Bit 6	Bit 5	Bit 4	Bit 3	Bit 2	Bit 1	Bit 0
Double Word	Byte 0	Least Significant Byte (LSB)							
	Byte 1								
	Byte 2								
	Byte 3	Most Significant Byte (MSB)							
Word	Byte 4	Not Used							
	Byte 5								
	Byte 6								
	Byte 7								

OUTPUT OPERATION

The output operation will be different depending on the configuration chosen for the output.

Output Operation		
Function	Mode Value	Description
Disabled	0	Putting a "0" in the mode disables the output. It is recommended to disable any outputs that aren't being used.
Digital	1	This puts the output into on/off positive switching mode.
Data	2	This puts the output into PWM control with a value of 0 - 4000 equaling 0 - 100% of the duty cycle. Two bytes are allocated for each of the PWM control messages with the first 12 bits (Word data type) being used for the value. See Table 6 in the Mode Operation Examples.
Percent	3	This puts the output into PWM control with a value of 0 - 1000 equaling 0 - 100.0% of the duty cycle. Two bytes are allocated for each of the PWM control messages with the first 12 bits (Word data type) being used for the value. See Table 7 in the Mode Operation Examples.
Current	4	This puts the output into PWM(i) current control with a value of 0 - 3000 equaling 0 - 3000mA. Two bytes are allocated for each of the PWM(i) control messages with the first 12 bits (Word data type) being used for the value. See Table 8 in the Mode Operation Examples.

Output Control Messages		
Function	Applicable Variants	Description
PWM1 Control Message	DP-40044-01	Outputs 1A, 1B, 2A, and 2B: Data, Percent, or Current control

PWM(i) Operation

The PWM(i) control has more status and control commands than the standard PWM control. The module takes a setpoint for the current control and closes the loop according to the values put into the Kp and Ki. The module reports the current reading on the Amp Data status message. PWM(i) control uses the "P" and "I" components of PID where Kp and Ki are the equation constants. The derivative parameter "D" is fixed at 0. Loop Tuning* (Kp and Ki) requires an understanding of Closed Loop Control.

* Recommended starting values: Kp = 70, Ki = 30.

STATUS MESSAGES

Status Messages			
Function	Name	Applicable Variants	Description
Module Status Message	STAT	ALL	Device configuration status
Fault Count Message	FAULT		Fault counter for listed FLT faults, non-resettable
Output Status Message	DPLF1	DP-40044-01	ON/OFF/FLT status for Output 1A – 2B and Sensor Power 3-4
		DP-40044-05	ON/OFF/FLT status for Output 1A – 4B
Input Power Message		DP-40044-02	ON/OFF/FLT status for Sensor Power 1-4
Device Information	DPLF2	ALL	Physical PCB configuration, battery V DC, and temperature

J1939 Configuration

Applicable Configurations by Variant

Command	Value	Configuration	DP-40044-01	DP-40044-02	DP-40044-05
0x51h	81	Port	X*	X	X
0x52h	82	Global	X	X	X
0x53h	83	I/O	X	X	X
0x54h	84	PWM(i)	X	N/A	N/A
0x55h	85	PWM(i)	X	N/A	N/A
0x57h	87	Counter/Encoder	X	X	N/A
0x5Dh	93	Hardware Output	X	N/A	N/A
0x5Ch	92	Sensor Power	X	N/A	N/A
0x5Bh	91	Variable Transmission Rate	X	X	X

* X indicates that there is an applicable message for this variant. Click on the X to jump to the corresponding page.

Command 0x52h & 0x53h (This message is used to set general parameters and global configuration of I/O):

- Configure which additional status messages transmitted.
- Command used to set the write configuration bit pair.
- Set the frequency of the PWM(i) outputs.
- Configure individual input and output modules.

Command 0x54h, 55h (This message needs to be sent until the message confirmation bit is set True):

- Configure the Kp and Ki for any PWM current controls.

Command 0x57h (This message needs to be written all the time if a person is controlling the counter. A person needs to keep the counter on and needs to be able to reset the count):

- Configure the counters/encoder if using these functions.

Command 0x5Ch & 0x5Dh (This message needs to be sent until the message confirmation bit is set True):

- Configure sensor power to source voltage (VBAT) or 5VDC.
- Configure sensor power to always on.
- Configure ports to standard, parallel or h-bridge outputs.

Command 0x5Bh (This message only needs to be written if changing the transmission rates of the digital or analog input(s) messages is desired):

- Configure the transmit rates.

Status messages - Status message 1 PGN (EF(Controller Source Address)):

- Status 1 – Factory default configuration returns a value of 1, this should not be on if a module has been configured.
- Status 2 – Configuration Saved returns a value of 1 if the alternate configuration was on (value of 1) and saved the configuration using “Save Configuration” in Command 52.
- Status 3 – Alternate configuration, a new configuration was made to the module but hasn’t been saved.
- Status 9-14 – Returns a value of 1 each time a Command message 52-5D is sent, to ensure each configuration has been sent. This is on for 1 second and then resets.

Command 0x51h (Outputs digital control and Input Port Sensor Power) messages need to be consistently sent.

DP-40044-01 Configuration Process

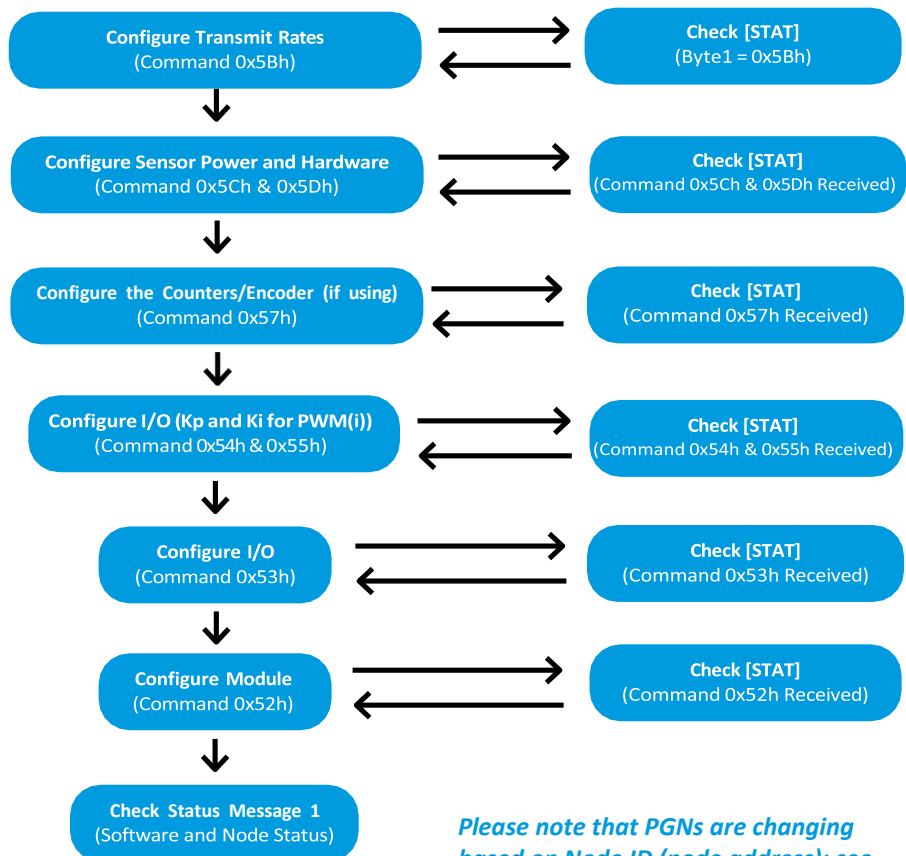

Please note that PGNs are changing based on Node ID (node address); see section “PGNs USED” for details.



Configuration messages on 0x52h-0x5Dh should only be sent until receipt is confirmed, DO NOT send continuously.

DP-40044-02 Configuration Process

Command 0x52h (This message is used to set general parameters and global configuration of I/O):

- Configure which additional status messages transmitted.
- Configure module for 24V DC operation.
- Command used to set the write configuration bit pair.
- Set the frequency of the PWM outputs.

Command 0x53h & 54h (This message needs to be sent until the message confirmation bit is set True):

- Configure individual input and output modes if they haven't been configured in Mode 1 and Mode 2 in Command 0x52h.

Command 0x57h (This message needs to be written all the time if a person is controlling the counter. A person needs to keep the counter on and needs to be able to reset the count):

- Configure the counters/encoder if using these functions.

Command 0x5Bh (This message only needs to be written if changing the transmission rates of the digital or analog input(s) messages is desired):

- Configure the transmit rates.

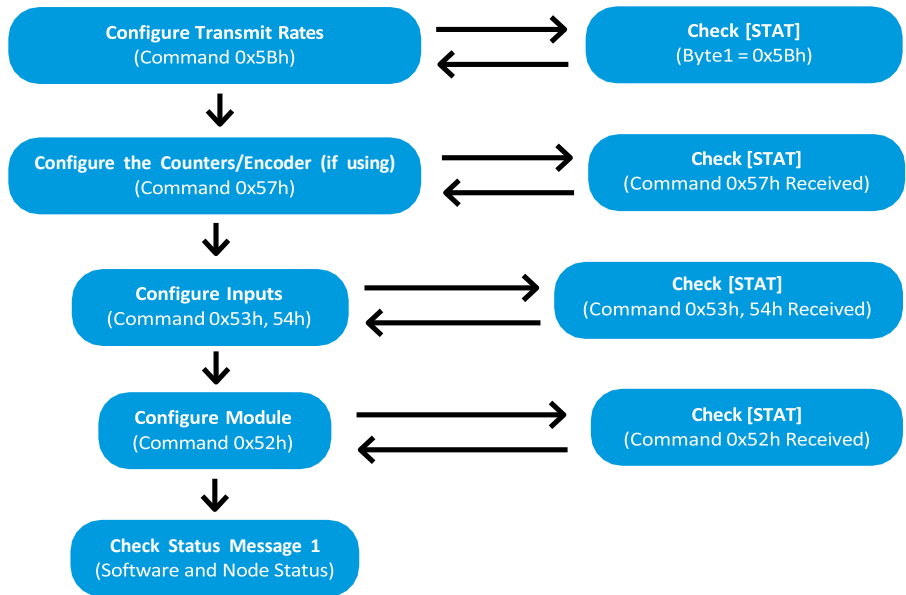

DP-40044-05 Configuration Process

Command 0x52h (This message is used to set general parameters and global configuration of I/O):

- Configure which additional status messages transmitted.
- Command used to set the write configuration bit pair.
- Set the frequency of the PWM outputs.

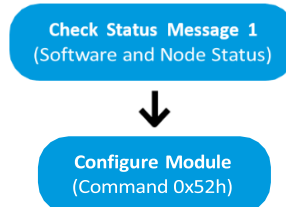

Configuration messages should only be sent until receipt is confirmed. **DO NOT** send continuously.

NOTES ON MODULE CONFIGURATION

PGN 61184 (0xEF00h) is the base message ID for destination-specific PGNs. This message is sent from the xtremeDBm to the controller. This message will not transmit until the receipt of CTRL1 from the controller and the controller SA can be identified.

NOTE: A controller cannot use SAs 0x00h or 0xFFh.

Example:

Controller is SA 92d (0x5Ch) and the module is at SA 217d (0xD9h).

The xtremeDBm (CTRL1) message sent to the module is 0xEF095Ch.

The xtremeDBm [STAT] message will go out as 0xEF5CD9h to the controller.

PGN 0xEF5C (61276d)

Inputs and outputs can be configured globally or individually. Both configuration types use the same PGN. PGN 61401 is used for multiple messages by use of a different value put into the "Command" byte of the data packet. This value is used as an index or pointer as to where the information goes in the module.

All PGNs are shown as module-configured with no jumpers (Offset = 0)

- Factory Default Config returns 1 in Status message 1-Status 1, this should not be on if the module has been configured.
- Default configuration does not require a Command 0x52h message to enable operation.
- Default operation of the module is on/off digital control. PWM control messages are not needed.
- Default operation of the module is digital positive inputs.

Proprietary A Response Message [STAT] (PGN 61184-Base)		
PGN (0xEF00 + CTRL1 SA)	Dec	Hex
Data Length	8	8
Priority: 6	24	0x18
EDP & DP	0	0
PDU Format	239	0xEF
PDU Specific	CTRL1 PGN 61401 SA	
SA - Response Base	217	0xD9
Transmission Repetition	50 mSec	
Message Timeout	Command 0x50h - 0x58h	

Control Message 1 / 0xEFD9h / PGN 61401									
Data Type		Bit 7	Bit 6	Bit 5	Bit 4	Bit 3	Bit 2	Bit 1	Bit 0
Byte	Byte 0	Command							
	Byte 1	Byte 1							
	Byte 2	Byte 2							
	Byte 3	Byte 3							
	Byte 4	Byte 4							
	Byte 5	Byte 5							
	Byte 6	Byte 6							
	Byte 7	Byte 7							

NOTE: Data Panel uses little-endian bit ordering



Base Address 224 (0xE0) is not recommended to be used in multiple module systems. Reserve for testing purposes.

CONFIGURING THE BAUD RATE AND SOURCE ADDRESS WITH THE MAGNET SWITCH

Before beginning the process, confirm that the module is NOT connected to a CAN communication network. The STAT LED should be blinking yellow, not a steady green color. The module should be connected to a power source. The port LEDs will act as indicators of Source Address (SA) offset or Baud Rate values during this process. This process does NOT configure the individual ports. SA offset values and Baud Rate values indicated by the Port LEDs are depicted in the image below.

To configure the SA and the Baud Rate using the magnet switch, press a magnet to the magnet switch, indicated by the ★ below, and hold for three seconds. While holding, the STAT LED will be a cyan color (not to be confused with blue or green), and upon holding for the three seconds, the STAT LED will turn white in color. Upon removing the magnet, the STAT LED will blink violet. The module has entered Configuration State One.

Configuration State One configures the SA. Pressing and removing the magnet will increment the SA offset by one. To save a particular offset, hold the magnet to the magnet switch for three seconds before removing. The STAT LED will turn from cyan to white, and upon removing the magnet, the STAT LED will blink pink. The module has entered Configuration State Two.

Configuration State Two configures the Baud Rate. Pressing and removing the magnet will oscillate the Baud Rate value between 250kb and 500kb. In order to save a particular baud rate, hold the magnet to the magnet switch for three seconds before removing. The STAT LED will turn from cyan to white, and upon removing the magnet, all the port LEDs will cycle to indicate that the module is rebooting and initializing.

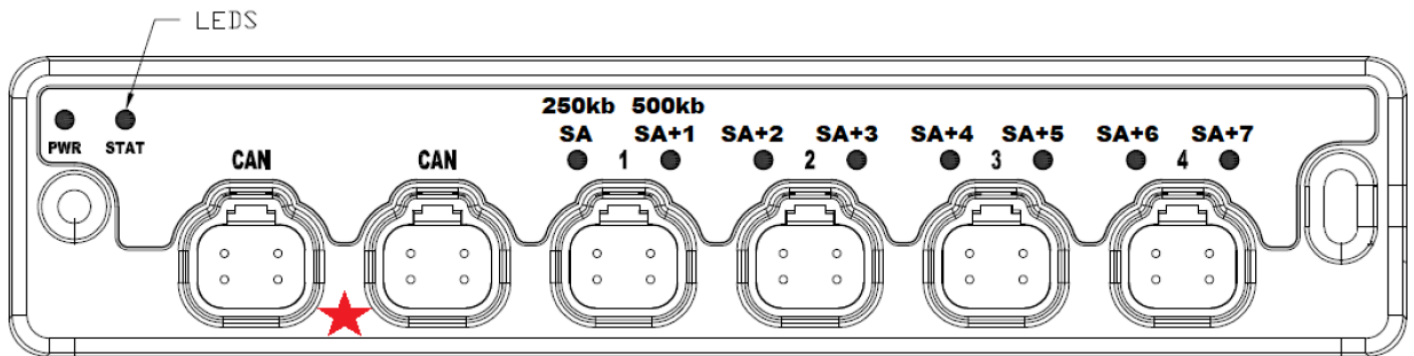

Offset	Source Address	
0	(0xD9h)	217
1	(0xDAh)	218
2	(0xDBh)	219
3	(0xDCh)	220
4	(0xDDh)	221
5	(0xDEh)	222
6	(0xDFh)	223
7	(0xE0h)	224



All devices on the same CAN network must have the same baud rate.

See page 28 for the command message details for setting the Source Address. Click here for [video guide](#).

Value 81 (Command 0x51h): All Variants

Command 0x51h (Outputs digital control and Inputs power control) and PWM control messages need to be consistently sent to prevent timeout.

Port Configuration / Output Control Message 1									
Data Type		Bit 7	Bit 6	Bit 5	Bit 4	Bit 3	Bit 2	Bit 1	Bit 0
Byte	Byte 0	Command							
2 bit	Byte 1	Output 2B		Output 2A		Output 1B		Output 1A	
	Byte 2	Output 4B		Output 4A		Output 3B		Output 3A	
	Byte 3	Spare							
	Byte 4	Spare							
	Byte 5	Input Power Port 4		Input Power Port 3		Input Power Port 2		Input Power Port 1	
	Byte 6	Spare							
Byte	Byte 7	Spare							

NOTE: Data Panel uses little-endian bit ordering

Name	Applicable Variant	Description
Command	All	Command for index pointer (0x51h)
Output 2B	DP-40044-01, -05	Turns the output on when in Digital Mode (not used when using any other mode)
Output 2A		
Output 1B		
Output 1A		
Output 4B		
Output 4A	DP-40044-05	
Output 3B		
Output 3A		
Input Power Port 4		
Input Power Port 3		
Input Power Port 2	DP-40044-02	Enable Input Sensor Power (00 = off), (01 = on)
Input Power Port 1		
Bytes 3-5, 7-8	DP-40044-01	N/A
Bytes 2-5, 7-8	DP-40044-02	
Byte 4-8	DP-40044-05	

PGN with SA offset and Command Value = 0x51h must be sent periodically to prevent sensor power outputs from timing out.

Value 82 (Command 0x52h): All Variants

Global Configuration									
Data Type		Bit 7	Bit 6	Bit 5	Bit 4	Bit 3	Bit 2	Bit 1	Bit 0
Byte	Byte 0	Command							
2 bit	Byte 1	Spare	Enable Status 2 Message		Enable Status 1 Message		Control Mode Reset		
	Byte 2	Spare	Analog Raw Value		Save Configuration		Spare		
	Byte 3	Spare							
Word	Byte 4	Low Byte FREQ1							
	Byte 5	High Byte FREQ1							
4 bit	Byte 6	Spare							
Byte	Byte 7	ID1							

NOTE: Data Panel uses little-endian bit ordering

Name	Applicable Variant	Description
Command	ALL	Command for index pointer (0x52h)
Enable Status 2 Message		Enables the constant transmission of status message 2 [DPLF2]
Enable Status 1 Message		Enables the constant transmission of status message 1 [DPLF1]
Control Mode Reset		Enables Controller Mode Output Reset
Analog Raw Value	DP-40044-01, -02	Sets all analog to be read in raw value as opposed to scaled (.005668/bit)
	DP-40044-05	N/A
Save Configuration	ALL	Saves the configuration to the module (otherwise changes only valid until a power cycle occurs), set to 1 to write configuration to module
Low Byte FREQ1	DP-40044-01	Sets the global configuration of the frequency for all channels. Value in decimal (40 - 1100 Hz). Example: 0xC8h = 200d = 200 Hz. Outputs will assume the default value if no other value is provided.
	DP-40044-02, -05	N/A
High Byte FREQ1	DP-40044-01	Sets the global configuration of the frequency for all channels. Value in decimal (40 - 1100 Hz). Example: 0xC8h = 200d = 200 Hz. Outputs will assume the default value if no other value is provided.
	DP-40044-02, -05	N/A
ID1	ALL	User defined byte for configuration ID, this will be transmitted in the STAT message

Value 83 (Command 0x53h): DP-40044-01, -02

I/O Configuration									
Data Type		Bit 7	Bit 6	Bit 5	Bit 4	Bit 3	Bit 2	Bit 1	Bit 0
Byte	Byte 0	Command							
4 bit	Byte 1	MODE1B				MODE1A			
	Byte 2	MODE2B				MODE2A			
	Byte 3	MODE3B				MODE3A			
	Byte 4	MODE4B				MODE4A			
	Byte 5	Spare							
	Byte 6	Spare							
	Byte 7	Spare							

NOTE: Data Panel uses little-endian bit ordering

DP-40044-01

Name	Description
Command	Command for index pointer (0x53h)
MODE1A	Sets the output configurations. Mode 0x0 = Disabled, 0xB = Digital ON/OFF, 0xC = Percent 0-100.0% (0-1,000), 0xD = Current (0-4,000 mA)
MODE1B	
MODE2A	
MODE2B	
MODE3A	Sets the input configurations. Mode 0x0 =Not Used, 0x1 =Digital Positive, 0x2 =Digital Ground, 0x3 =4-20 mA, 0x4 =0...5 V DC, 0x5 =0...10 V DC, 0x6 =0...32 V DC, 0x7 =Frequency, 0x8 =Counter, 0x9 =Ratiometric, 0xA =Encoder
MODE3B	
MODE4A	
MODE4B	

DP-40044-02

Name	Description
Command	Command for index pointer (0x53h)
MODE1A	Sets the input configurations. Mode 0x0 =Disabled, 0x1 =Digital Positive, 0x2 =Digital Ground
MODE2A	
MODE3A	
MODE4A	
MODE1B	Sets the input configurations. Mode 0x0 =Disabled, 0x1 =Digital Positive, 0x2 =Digital Ground, 0x3 =4-20 mA, 0x4 =0...5 V DC, 0x5 =0...10 V DC, 0x6 =0...32, 0x7 =Frequency, 0x8 =Counter, 0x9 =Ratiometric, 0xA =Encoder
MODE2B	
MODE3B	
MODE4B	

Value 84 (Command 0x54h): DP-40044-01

PWM(i) Configuration									
Data Type		Bit 7	Bit 6	Bit 5	Bit 4	Bit 3	Bit 2	Bit 1	Bit 0
Byte	Byte 0	Command							
4 bit	Byte 1	Port 1A Kp							
Byte	Byte 2	Port 1A Ki							
	Byte 3	Port 1B Kp							
	Byte 4	Port 1B Ki							
	Byte 5	Port 2A Kp							
	Byte 6	Port 2A Ki							
	Byte 7	Spare							

NOTE: Data Panel uses little-endian bit ordering

Name	Description
Command	Command for index pointer (0x54h)
Port 1A Kp	Output proportional set point (0-250 = 0-2.50, >250=0) default 100
Port 1B Kp	
Port 2A Kp	
Port 1A Ki	Output integral set point (0-250 = 0-2.50, >250=0) default 100
Port 1B Ki	
Port 2A Ki	

Value 85 (Command 0x55h): DP-40044-01

PWM(i) Configuration									
Data Type		Bit 7	Bit 6	Bit 5	Bit 4	Bit 3	Bit 2	Bit 1	Bit 0
Byte	Byte 0	Command							
	Byte 1	Port 2B Kp							
	Byte 2	Port 2B Ki							
	Byte 3	Spare							
	Byte 4	Spare							
	Byte 5	Spare							
	Byte 6	Spare							
	Byte 7	Spare							

NOTE: Data Panel uses little-endian bit ordering

Name	Applicable Variants	Description
Command	DP-40044-01	Command for index pointer (0x55h)
Port 2B Kp		Output proportional set point (0-250 = 0-2.50, >250=0) default 100
Port 2B Ki		Output integral set point (0-250 = 0-2.50, >250=0) default 100
Byte 8		N/A

Value 87 (Command 0x57h): DP-40044-01, -02

Counter Configuration									
Data Type		Bit 7	Bit 6	Bit 5	Bit 4	Bit 3	Bit 2	Bit 1	Bit 0
Byte	Byte 0	Command							
2 bit	Byte 1	Counter 3X Enable Output 1A		Counter 3X Enable Overflow		Counter 3X Reset		Counter 3X On/Off	
	Byte 2	Counter 4X Enable Output 2A		Counter 4X Enable Overflow		Counter 4X Reset		Counter 4X On/Off	
	Byte 3	Spare		Spare		Spare		Select B Channel	
Word	Byte 4	Counter 3X Setpoint (Low Byte)							
	Byte 5	Counter 3X Setpoint (High Byte)							
	Byte 6	Counter 4X Setpoint (Low Byte)							
	Byte 7	Counter 4X Setpoint (High Byte)							

NOTE: Data Panel uses little-endian bit ordering

Name	Applicable Variant	Description
Command	DP-40044-01, -02	Command for index pointer (0x57h)
Counter 3X Enable Output 1A*	DP-40044-01	Enable Output 1A when Counter 3X is enabled and set point hasn't been reached, 00 = Off, 01 = On (not used in encoder mode)
	DP-40044-02	N/A
Counter 3X Enable Overflow	DP-40044-01, -02	Enable Counter 3X Overflow, count continues after setpoint is achieved, 00 = Off, 01 = On (not used in encoder mode)
Counter 3X Reset		Reset Counter 3X, 00 = Off, 01 = On (used in encoder mode)
Counter 3X On/Off		Enable Counter 3X, 00 = Off, 01 = On (used in encoder mode)
Counter 4X Enable Output 2A**	DP-40044-01	Enable Output 2A when Counter 4X is enabled and setpoint hasn't been reached, 00 = Off, 01 = On (not used in encoder mode)
	DP-40044-02	N/A
Counter 4X Enable Overflow	DP-40044-01, -02	Enable Counter 4X Overflow, count continues after setpoint is achieved, 00 = Off, 01 = On (not used in encoder mode)
Counter 4X Reset		Reset Counter 4X, 00 = Off, 01 = On (used in encoder mode)
Counter 4X On/Off		Enable Counter 4X, 00 = Off, 01 = On (used in encoder mode)
Select B Channel	DP-40044-01	If feature is available in hardware, this bit will configure these features on the B channel. If disabled, this bit will configure the features on the A channel.
Counter 3X Set Point*	DP-40044-01, -02	Total count to trigger the disabling of the output (1A or 2A) and stop counting unless overflow is enabled. If overflow is enabled, the counters will keep incrementing.
Counter 4X Set Point**		

*Set a value of 1 to "Counter 3A Enable Out 1A" provides an Enable function for Output 1A. Output 1A is disabled when counter > = Set Point.

**Set a value of 1 to "Counter 4A Enable Out 2A" provides an Enable function for Output 2A. Output 2A is disabled when counter > = Set Point.

Value 91 (Command 0x5Bh): All Variants

Use this command only if you want the change the default transmission rates of the messages as listed. Caution should be used to manage bus load and confirm operation. This message is also the **Status Message 1 (Response to Command 0x5Bh) with a PGN of 61184 (0xEF(CSA))**.

Variable Transmission Rate Configuration									
Data Type		Bit 7	Bit 6	Bit 5	Bit 4	Bit 3	Bit 2	Bit 1	Bit 0
Byte	Byte 0	Command							
	Byte 1	DIGIN							
	Byte 2	AD2							
	Byte 3	AD3							
	Byte 4	Spare							
	Byte 5	Spare							
	Byte 6	Spare							
	Byte 7	Spare							

NOTE: Data Panel uses little-endian bit ordering

Name	Description
Command	Command for index pointer (0x5Bh)
DIGIN	Message [DIGIN] Transmit Cycle Time
AD2	Message [AD2] Transmit Cycle Time
AD3	Message [AD3] Transmit Cycle Time
Bytes 4-7	Spare – Set to 0xFFh.

Resolution	10 mSec/Bit
Offset	0
Data Range	10 mSec – 2500 mSec [1 – 250]
Example	180 = 1800 mSec or 1.8 seconds

Value 92 (Command 0x5Ch): DP-40044-01

Sensor Power Configuration									
Data Type		Bit 7	Bit 6	Bit 5	Bit 4	Bit 3	Bit 2	Bit 1	Bit 0
Byte	Byte 0	Command							
	Byte 1	P4 Sensor Power Always ON	P3 Sensor Power Always ON		Spare		Spare		
2 bit	Byte 2	Port 3 5V Sensor Power		Spare		Spare		Spare	
	Byte 3	Spare		Spare		Spare		Port 4 5V Sensor Power	
Word	Byte 4	Spare							
	Byte 5	Spare							
	Byte 6	Spare							
	Byte 7	Spare							

NOTE: Data Panel uses little-endian bit ordering

Name	Applicable Variants	Description
Command	DP-40044-01	Command for index pointer (0x5Ch)
Port [X] Sensor Power Always ON		Set port sensor power to always on. Mode 0x0 = OFF, 0x1 = ON
Port [X] 5V Sensor Power		Set Port Sensor Power to 5VDC. Mode 0x0 = 8-32VDC Sensor Power (VBAT), 0x1 = 5VDC Sensor Power
Bytes 4-7		N/A

Value 93 (Command 0x5Dh): DP-40044-01

Hardware Configuration									
Data Type		Bit 7	Bit 6	Bit 5	Bit 4	Bit 3	Bit 2	Bit 1	Bit 0
Byte	Byte 0	Command							
	Byte 1	Port 2 Output Configuration				Port 1 Output Configuration			
2 bit	Byte 2	Spare							
	Byte 3	Spare							
Word	Byte 4	Spare							
	Byte 5	Spare							
	Byte 6	Spare							
	Byte 7	Spare							

NOTE: Data Panel uses little-endian bit ordering. For more information regarding Parallel and H-Bridge Modes, refer to [Page 14](#).

Name	Applicable Variants	Description
Command	DP-40044-01	Command for index pointer (0x5Dh)
Port 1 Output Configuration		Sets the port hardware configuration. Mode 0x0 =Standard Enable, 0x1 =Parallel Enable, 0x2 =H-Bridge Enable
Port 2 Output Configuration		
Bytes 4-7		N/A

Mode	Output Operation	Notes
0x0h	Standard Enable	Normal Operation
0x1h	Parallel Enable	Pin A & B drive load in Parallel
0x2h	H-Bridge Enable	Pins A & B drive load as H-Bridge

Value 226 (Command 0xE2h): All CANBUS Variants

Set Source Address									
Data Type		Bit 7	Bit 6	Bit 5	Bit 4	Bit 3	Bit 2	Bit 1	Bit 0
Byte	Byte 0	Command							
	Byte 1	Unlock Key 1 = 0x51h							
	Byte 2	Unlock Key 2 = 0x50h							
	Byte 3	Source Address: Valid Range = 0xD9h to 0xE0h							
	Byte 4	Bit Rate = 250-500 (BAUD RATE Range = 250k-500k)							
	Byte 5	0xFFh							
	Byte 6	0xFFh							
	Byte 7	0x11b	0x11b	0x11b	0x11b	0x11b	0x11b	0x11b	0x11b

NOTE: Data Panel uses little-endian bit ordering
See page 22 for instructions on setting the Source Address using the magnet switch

PGNs USED

Depending on the selected Node SA, the PGNs and source address will be different for the module. The section below shows which are used for each Node SA.

Source Address and SA-Specific Values

Source Address	217	218	219	220	221	222	223	224
SA	D9	DA	DB	DC	DD	DE	DF	E0
Control	EFD9	EFDA	EFDB	EFDC	EFDD	EFDE	EFDF	EFE0
PWM1	9DD9	9DDA	9ddb	9DDC	9DDD	9DDE	9DDF	9DE0

NOTE: Reference provided SA values in the table above when building the PGN messages in the table below

	PGN Value	Default Transmit Rate	Priority	DP-40044-01	DP-40044-02	DP-40044-05
Control	61401	50 mSec	-	X	X	X
Module Status [STAT]	61184	50 mSec	6	EF(CSA**)	EF(CSA)	EF(CSA)
Fault Count [FAULT]	65510	200 mSec	6	FFE6***	FFE6	FFE6
I/O Status [DPLF1]	65531	50 mSec	6	FFFB	FFFB	FFFB
Device Information [DPLF2]	65532	200 mSec	6	FFFC	FFFC	FFFC
Digital I/O Status [DIGIN]	65301	50 mSec	6	FF15	FF15	N/A
Analog I/O 1A-2B [AD2]	65302	50 mSec	6	FF16	FF16	N/A
Analog I/O 3A-4B [AD3]	65303	50 mSec	6	FF17	FF17	N/A
Freq./Counter Inputs 1 [FREQ1]	65306	50 mSec	6	FF1A	N/A	N/A
Freq./Counter Inputs 2 [FREQ2]	65307	50 mSec	6	FF1B	FF1B	N/A
PWM1	65308	50 mSec	-	9D(SA*)	N/A	N/A

*See Source Address and SA-Specific Values table above

**CSA: Controller Source Address

*** Click on the X or FFXX to jump to the corresponding page.

PGN 61184 (0xEF(CSA)): All Variants

Module Status Message (STAT Proprietary A Default Response Message)										
Data Type		Bit 7	Bit 6	Bit 5	Bit 4	Bit 3	Bit 2	Bit 1	Bit 0	
Byte	Byte 0	Software Version								
	Byte 1	Software Revision								
2 bit	Byte 2	Status 4	Status 3		Status 2		Status 1			
	Byte 3	Spare				Status 6		Status 5		
Byte	Byte 4	Fault Code								
	Byte 5	User ID								
2 bit	Byte 6	Status 12	Status 11		Status 10		Status 9			
2 bit, 4 bit	Byte 7	Spare				Status 14		Spare		

NOTE: Data Panel uses little-endian bit ordering

Name	Applicable Variant	Description
Software Version	ALL	Version of the current software Byte 1 >0x1Fh (0x20h-0xFFh) indicates an alternate format for Bytes 2-8. This is used for response on alternate command messages.
Software Revision		Revision of the current software
Status 4		Node Alive
Status 3		Alternate Configuration Received
Status 2		Configuration Saved (module is configured)
Status 1		Factory Default Configuration
Status 6	ALL	Fault Count not Zero
Status 5		Node Fault Present
Fault Code		Active fault code
User ID		The User ID of the module configured in CTRL1 message
Status 12	DP-40044-01	True when Message Command = 0x55h received
	DP-40044-02, -05	N/A
Status 11	DP-40044-01	True when Message Command = 0x54h received
	DP-40044-02, -05	N/A
Status 10	DP-40044-01, -02	True when Message Command = 0x53h received
	DP-40044-05	N/A
Status 9	ALL	True when Message Command = 0x52h received
Status 14	DP-40044-01, -02	True when Message Command = 0x57h received
	DP-40044-05	N/A

PGN 65510 (0xFFE6): All Variants

Fault Count Message (FAULT)									
Data Type		Bit 7	Bit 6	Bit 5	Bit 4	Bit 3	Bit 2	Bit 1	Bit 0
Byte	Byte 0	Fault Counter F1							
	Byte 1	Fault Counter F2							
	Byte 2	Fault Counter F3							
	Byte 3	Fault Counter F4							
	Byte 4	Fault Counter F5							
	Byte 5	Fault Counter F6							
	Byte 6	Fault Counter F7							
	Byte 7	Spare							

NOTE: Data Panel uses little-endian bit ordering

PGN 65531 (0xFFFB): All Variants

Output Status Message (DPLF1)									
Data Type		Bit 7	Bit 6	Bit 5	Bit 4	Bit 3	Bit 2	Bit 1	Bit 0
2 bit	Byte 0	Spare		Spare		Spare		Magnet Sensor	
	Byte 1	Spare							
	Byte 2	I/O Status 2B		I/O Status 2A		I/O Status 1B		I/O Status 1A	
	Byte 3	I/O Status 4B		I/O Status 4A		I/O Status 3B		I/O Status 3A	
	Byte 4	Sensor Power 2		Sensor Power 1		Spare		Spare	
	Byte 5	Spare		Spare		Sensor Power 4		Sensor Power 3	
	Byte 6	Spare							
Byte	Byte 7	Save Configuration Counter							

NOTE: Data Panel uses little-endian bit ordering

Name	Applicable Variant	Description	
Magnet Sensor	ALL	Status of magnet switch, (00 = off), (01 = on), (10 = fault)	
Output Status 1A		Status of input/output, (00 = off), (01 = on), (10 = fault)	
Output Status 1B			
Output Status 2A			
Output Status 2B			
Output Status 3A			
Output Status 3B			
Output Status 4A			
Output Status 4B			
Sensor Power 1			DP-40044-02
Sensor Power 2			
Sensor Power 3	DP-40044-01, -02		
Sensor Power 4			
Save Configuration Counter	ALL	Count of how many times the configuration has been saved to the module	

PGN 65532 (0xFFFC): All Variants

Device Information (DPLF2)									
Data Type		Bit 7	Bit 6	Bit 5	Bit 4	Bit 3	Bit 2	Bit 1	Bit 0
Byte	Byte 0	CNFG1							
	Byte 1	CNFG2							
10 bit	Byte 2	VBAT							
	Byte 3	Spare		Spare		VBAT			
Word	Byte 4	TEMP							
	Byte 5	Spare		Spare		TEMP			
Byte	Byte 6	CNFG3							
	Byte 7	Spare							

NOTE: Data Panel uses little-endian bit ordering

Name	Description
CNFG1	Hardware Configuration
CNFG2	PCB Assembly Revision
VBAT	Battery Voltage 100mV/bit, data range 0 - 320 (32.0V DC max).
TEMP	Module Temperature, -100.0°F to +300.0°F, data range 0 – 4000 bits.
CNFG3	Additional Configuration

PGN 65301 (0xFF15): All Variants

Digital I/O Status Message (DIGIN)									
Data Type		Bit 7	Bit 6	Bit 5	Bit 4	Bit 3	Bit 2	Bit 1	Bit 0
2 bit	Byte 0	Digital I/O 2B		Digital I/O 2A		Digital I/O 1B		Digital I/O 1A	
	Byte 1	Digital I/O 4B		Digital I/O 4A		Digital I/O 3B		Digital I/O 3A	
	Byte 2	Spare							
	Byte 3	Spare							
	Byte 4	Sensor Power 4		Sensor Power 3		Sensor Power 2		Sensor Power 1	
	Byte 5	Spare							
Byte	Byte 6	IGN REF (Low Byte)							
	Byte 7	IGN REF (High Byte)							

NOTE: Data Panel uses little-endian bit ordering

Name	Applicable Variant	Description
Digital I/O 1A	ALL	Status of input/output, (00 = off), (01 = on), (10 = fault)
Digital I/O 1B		
Digital I/O 2A		
Digital I/O 2B		
Digital I/O 3A		
Digital I/O 3B		
Digital I/O 4A		
Digital I/O 4B		
Sensor Power 1	DP-40044-02	Status of Sensor Port Power, (00 = off), (01 = on), (10 = fault)
Sensor Power 2		
Sensor Power 3	DP-40044-01, 02	
Sensor Power 4		
IGN REF		12 Bit

PGN 65302 (0xFF16): DP-40044-01, -02

Analog I/O 1A-2B Status Message (AD2)									
Data Type		Bit 7	Bit 6	Bit 5	Bit 4	Bit 3	Bit 2	Bit 1	Bit 0
Word	Byte 0	Analog I/O 1A (LOW BYTE)							
	Byte 1	Analog I/O 1A (HIGH BYTE)							
	Byte 2	Analog I/O 1B (LOW BYTE)							
	Byte 3	Analog I/O 1B (HIGH BYTE)							
	Byte 4	Analog I/O 2A (LOW BYTE)							
	Byte 5	Analog I/O 2A (HIGH BYTE)							
	Byte 6	Analog I/O 2B (LOW BYTE)							
	Byte 7	Analog I/O 2B (HIGH BYTE)							

NOTE: Data Panel uses little-endian bit ordering

Name	Description
Analog I/O 1A	<p>Input Modes: Mode 0x3= 4-20mA (4,000-20,000), 0x4= 0-5V DC (0-5,000), 0x5= 0-10V DC (0-10,000), 0x6= 0-32V DC (0-32,000), 0x9= Ratiometric (0-100.0% of P0 V DC)</p> <p>Output modules report current. 0xBh=Digital (0-22 Amps)</p>
Analog I/O 2A	
Analog I/O 1B	
Analog I/O 2B	

PGN 65303 (0xFF17): DP-40044-01, -02

Analog I/O 3A-4B Status Message (AD3)									
Data Type		Bit 7	Bit 6	Bit 5	Bit 4	Bit 3	Bit 2	Bit 1	Bit 0
Word	Byte 0	Analog I/O 3A (LOW BYTE)							
	Byte 1	Analog I/O 3A (HIGH BYTE)							
	Byte 2	Analog I/O 3B (LOW BYTE)							
	Byte 3	Analog I/O 3B (HIGH BYTE)							
	Byte 4	Analog I/O 4A (LOW BYTE)							
	Byte 5	Analog I/O 4A (HIGH BYTE)							
	Byte 6	Analog I/O 4B (LOW BYTE)							
	Byte 7	Analog I/O 4B (HIGH BYTE)							

NOTE: Data Panel uses little-endian bit ordering

Name	Description
Analog I/O 3A	<p>Input Modes: Mode 0x3= 4-20mA (4,000-20,000), 0x4= 0-5V DC (0-5,000), 0x5= 0-10V DC (0-10,000), 0x6= 0-32V DC (0-32,000), 0x9= Ratiometric (0-100.0% of P0 V DC)</p> <p>Output modules report current. 0xBh=Digital (0-22 Amps)</p>
Analog I/O 4A	
Analog I/O 3B	
Analog I/O 4B	

PGN 65306 (0xFF1A): DP-40044-01

Frequency/Counter/Encoder Inputs 3A-3B Status Message (FREQ1)									
Data Type		Bit 7	Bit 6	Bit 5	Bit 4	Bit 3	Bit 2	Bit 1	Bit 0
Word	Byte 0	Status 1 (LOW BYTE)							
	Byte 1	Status 1 (HIGH BYTE)							
	Byte 2	Status 2 (LOW BYTE)							
	Byte 3	Status 2 (HIGH BYTE)							
	Byte 4	Status 3 (LOW BYTE)							
	Byte 5	Status 3 (HIGH BYTE)							
	Byte 6	Status 4 (LOW BYTE)							
	Byte 7	Status 4 (HIGH BYTE)							

NOTE: Data Panel uses little-endian bit ordering

Name	Frequency Mode	Counter Mode	Encoder Mode
Status 1	Hz Count Input Port 3A	Count Input Port 3A	LSB: BYTE 0
Status 2	Duty Cycle Input Port 3A	Setpoint Input Port 3A	MSB: BYTE 3
Status 3	N/A	Count Input Port 3B	N/A
Status 4	N/A	Setpoint Input Port 3B	N/A

PGN 65307 (0xFF1B): DP-40044-01

Frequency/Counter Inputs 3A-4A Status Message (FREQ2)									
Data Type		Bit 7	Bit 6	Bit 5	Bit 4	Bit 3	Bit 2	Bit 1	Bit 0
Word	Byte 0	Status 1 (LOW BYTE)							
	Byte 1	Status 1 (HIGH BYTE)							
	Byte 2	Status 2 (LOW BYTE)							
	Byte 3	Status 2 (HIGH BYTE)							
	Byte 4	Status 3 (LOW BYTE)							
	Byte 5	Status 3 (HIGH BYTE)							
	Byte 6	Status 4 (LOW BYTE)							
	Byte 7	Status 4 (HIGH BYTE)							

NOTE: Data Panel uses little-endian bit ordering

Name	Frequency Mode	Counter Mode	Encoder Mode
Status 1	Hz Count Input Port 4A	Count Input Port 4A	LSB: BYTE 0
Status 2	Duty Cycle Input Port 4A	Setpoint Input Port 4A	MSB: BYTE 3
Status 3	N/A	Count Input Port 4B	N/A
Status 4	N/A	Setpoint Input Port 4B	N/A

PGN 65307 (0xFF1B): DP-40044-02

Frequency/Counter/Encoder Inputs 4A-4B Status Message (FREQ2)									
Data Type		Bit 7	Bit 6	Bit 5	Bit 4	Bit 3	Bit 2	Bit 1	Bit 0
Word	Byte 0	Status 1 (LOW BYTE)							
	Byte 1	Status 1 (HIGH BYTE)							
	Byte 2	Status 2 (LOW BYTE)							
	Byte 3	Status 2 (HIGH BYTE)							
	Byte 4	Status 3 (LOW BYTE)							
	Byte 5	Status 3 (HIGH BYTE)							
	Byte 6	Status 4 (LOW BYTE)							
	Byte 7	Status 4 (HIGH BYTE)							

NOTE: Data Panel uses little-endian bit ordering

Name	Frequency Mode	Counter Mode	Encoder Mode
Status 1	Hz Count Input Port 3A	Count Input Port 3A	LSB: BYTE 0
Status 2	Duty Cycle Input Port 3A	Setpoint Input Port 3A	MSB: BYTE 3
Status 3	Hz Count Input Port 4A	Count Input Port 4A	N/A
Status 4	Duty Cycle Input Port 4A	Setpoint Input Port 4A	N/A

PGN 40192 + SA (0x9D(SA*)): DP-40044-01

PWM1 Control Message									
Data Type		Bit 7	Bit 6	Bit 5	Bit 4	Bit 3	Bit 2	Bit 1	Bit 0
Word	Byte 0	**Control Output 1A							
	Byte 1	**H-Bridge 1 Direction Command				**Control Output 1A			
	Byte 2	Control Output 1B							
	Byte 3	Spare				Control Output 1B			
	Byte 4	**Control Output 2A							
	Byte 5	**H-Bridge 2 Direction Command				**Control Output 2A			
	Byte 6	Control Output 2B							
	Byte 7	Spare				Control Output 2B			

NOTE: Data Panel uses little-endian bit ordering

* See *Source Address and SA-Specific Values* table for offset values

** Used when [Port Hardware Configuration](#) is set to 'H-Bridge Mode'

Name	Data Type	Description
**Control Output 1A	12 bits	Sets the PWM output duty cycle of the corresponding output: PWM: 0-100% (0-1000), PWM(i): 0-4Amps (0-4000), **H-bridge: 0-100% (0-1000)
Control Output 1B		
**Control Output 2A		
Control Output 2B		
**H-Bridge-1 Direction Command	4 bits	**Sets the direction of current flow for the h-bridge. 0x0=Coast, 0x1=Forward, 0x2=Reverse, 0x4=Brake, 0xF=Maintain previous state
**H-Bridge-2 Direction Command		

Programming/Firmware Notes

All modules are capable of in-the-field firmware updates with the use of the xtremeDB® Programming Kit (DP-34005-12) or the [PEAK-System Technik PCAN-USB Adapter](#).

- The Block Tool is the software used to configure xtremeDBm® blocks. Please reference the Block Tool Quickstart Guide for instructions.
- DPLoader is the software used to download the firmware to xtremeDBm® blocks. Please reference the DPLoader Quickstart Guide for instructions.
- DPNPlayer is the software used to parse DPN and SPN into readable numbers and display messages from a CANBUS network. Please reference the DPNPlayer Quickstart Guide for instructions.

Accepted Accessories

Parts and equipment from other manufacturers can cause functional impairments and product damage. See below for the recommended accessories.



**4 Pin Port Dummy Plug
DP-34042-401**
Seals any unused ports.



**4 Pin CAN Terminating Plug
DP-34042-402**
120 Ohm terminating resistor
on pin 2 and pin 4.



**Programming Kit
DP-34005-12**

Paired with the xtremeDB® Block Tool, the DP-34005-12 programming kit makes it possible to send configuration code directly to the xtremeDB® block. No need to go hunting through CAN tables; it's all here, ideal for large systems or multiple systems that require a considerable number of blocks working together. This kit is recommended for CANopen protocols. DPLogic requires the use of this kit. Our software (aside from DPLogic) is compatible with PCAN interfaces, which is ideal for CAN J1939 protocols.

Warranty and Liability Claims

Data Panel Corporation warrants the original purchaser of its products that the products are free of defects in materials and workmanship, when operated under normal conditions and in accordance with accepted industry recommended practices. The standard warranty period is 12 months from the date the product is first put into service but not to exceed 18 months from the date of shipment.

Products must be returned, freight prepaid, to Data Panel for inspection. A Return Material Authorization (RMA) number must be obtained from that location before shipment is made, and clearly indicated on the shipping package. Product must be received within 3 months of the claim as per the requirements of the Returned Goods Process, which is considered to be part of the warranty. Data Panel reserves the right to repair or replace any product found to be under warranty. This warranty policy does not provide for a refund or credit for defective material.

This warranty is null and void if in the judgment of Data Panel, the part had been used in the wrong application, damaged, im properly maintained or repaired, subjected to inappropriate environmental and operating conditions, repaired by a non-approved party without prior authorization, not used in accordance with the operational and service recommendations, or repaired with other then approved parts.

This warranty is in lieu of all other warranties, express or implied and may be varied only by a separate agreement signed by duly authorized representatives of Data Panel Corp. Data Panel makes no warranty of merchantability of fitness for a particular purpose. Data Panel's entire and exclusive liability and the buyers exclusive and sole remedy, in connection with the consequential damages, including loss of use or travel, labor or material cost to remove or reinstall the product, should under no circumstances exceed the original cost for the products for which liability claimed.

Data Panel and Murrelektronik have checked the contents of this technical documentation for conformity with the hardware or software described. Deviations cannot be excluded in individual cases, which is why Data Panel and Murrelektronik exclude the warranty for the correctness of the contents and the liability for errors, in particular for complete conformity. The limitation of liability does not apply insofar as the cause of damage is due to intent and/or gross negligence. Insofar as a material contractual obligation has been breached due to slight negligence, the liability of Data Panel and Murrelektronik shall be limited to the damage typically incurred.

We reserve the right to make technical and content-related changes. We recommend that you check at regular intervals whether this documentation has been updated, as corrections that may become necessary, for example, as a result of technical developments, are regularly incorporated by Data Panel on a regular basis. We are always grateful for suggestions for improvement.

To the maximum extent permitted by applicable law, in no event shall Data Panel, Corp. or Murrelektronik, Inc. be liable for any special, incidental, indirect, or consequential damages whatsoever (including, but not limited to, damages for loss of profits or confidential or other information, for business interruption, for personal injury, for loss of privacy, for failure to meet any duty including of good faith or of reasonable care, for negligence, and for any other pecuniary or other loss whatsoever) arising out of or in any way related to the use of or inability to use the software product, the provision of or failure to provide support services, or otherwise under or in connection with any provision of this End User License, even in the event of the fault, tort (including negligence), strict liability, breach of contract or breach of warranty of Data Panel, Corp or Murrelektronik, Inc. or any supplier, and even if Data Panel, Corp. or Murrelektronik, Inc. or any supplier has been advised of the possibility of such damages.

Message Location Within This Document

Network Protocol	Message ID	Alternate ID	Message Function	Page(s)
J1939	Command Messages			
	81	0x51h	Sensor Control/Output Control Message 1	23
	82	0x52h	Global Configuration	24
	83	0x53h	I/O Configuration	25
	84	0x54h	I/O and PWM(i) Configuration	26
	85	0x55h	PMW(i) Configuration	27
	87	0x57h	Counter Configuration	28
	93	0x5Dh	Output Hardware Configuration	30
	92	0x5Ch	Sensor Power Configuration	29
	91	0x5Bh	Variable Transmission Rate	29
	PGN Status Messages			
	61184	(EF(CSA))	Module Status	32
	65510	FFE6	Fault Count	33
	65531	FFF8	Output Status/Input Power Status	33
	65532	FFFC	Device Information	34
	65301	FF15	Digital I/O Status	35
	65302	FF16	Analog I/O Status 1A-2B	36
	65303	FF17	Analog I/O Status 3A-4B	36
	65306	FF1A	Frequency/Counter/Encoder Inputs 1	37
	65307	FF1B	Frequency/Counter/Encoder Inputs 2	38
40192	(9D(SA))	PWM1 Control Message	38	

Glossary

Term	Definition
Analog Input	A variable voltage or current input from an external sensor
Baud	Abbreviation: Bd = Unit of measurement for speed in data transmission
BUS	Serial data transmission of several participants on the same line
Byte	Term from IEC 61158, corresponds to 1 byte or 8 bits
CAN	Controller Area Network
CANopen	CANopen is a standard of the CiA (CAN in Automation)
Counter	A variable that counts rising edge pulses
DC	Direct Current
Digital Input	Either a positive or ground input, binary ON or OFF
Digital Output	A positive voltage output, binary ON or OFF
EMCY	Emergency messages in CANopen
Enable 24V DC	Enables the low and over voltage fault limits for 24V DC system, otherwise feeding 24V DC to 12V DC system would cause system over voltage error. This is also used for the output overcurrent and short circuit detection.
Encoder	Device using two digital signals to count movement and direction
FREQ1	Sets the global configuration of the frequency for all channels. Value in decimal (40 - 1100 Hz). Example: 0xC8h = 200d = 200 Hz. Outputs will assume the default value if no other value is provided.
H-Bridge	A simple circuit used for bidirectional c DC loads, usually motors
ID1	This is used to give a reference number to the node that will be transmitted back in Status Message 1-User ID. Default as 0, please note this User ID is not "the" node ID (node address), please see "Configuring the Node ID" for setting node address.
LED	Light Emitting Diode
Mode 1	Configure all the outputs at the same time, override Command 0x53h.
Mode 2	Configure all the inputs at the same time, override Command 0x53h and 0x54h
Node	Participant in the network
Node ID	Address of CANopen devices in the CAN network
Node SA	Source Address of a J1939 device for identification purposes
PLC	Programmable Logic Controller
Process	Set of interrelated means and activities that transform inputs into outputs
PWM	Pulse Width Modulation
PWM(i)	PWM(i) or closed loop current compensation is an option that will compensate for changing resistance in electrical output loads. This is particularly useful for valve coils where the mechanical properties of the coils vary greatly with temperature change which can create fluctuation in machine control over the course of the working day. Our PWM(i) outputs will automatically adjust the current output to compensate which means that the electrical setpoint of the output remains more predictable and constant.
Ratiometric	I/O data presented as a percentage of battery voltage

Mode Operation Examples

Analog input readings shown below can be found using PGN 65302 ([0xFF16](#)) and PGN 65303 ([0xFF17](#)). PWM Output control messages are sent via PGN 65308 ([0xFF1C](#)).

INPUT MODE 3

Using this mode, the input port will report analog values in 4-20mA with a value of 4,000 - 20,000 = 4,000 - 20,000 micro amps. A word is allocated for this input. The 1st byte is the low byte and the 2nd byte is the high byte.

Table 1																	
Example	Second Byte (High Byte)								First Byte (Low Byte)								
	Bit 7	Bit 6	Bit 5	Bit 4	Bit 3	Bit 2	Bit 1	Bit 0	Bit 7	Bit 6	Bit 5	Bit 4	Bit 3	Bit 2	Bit 1	Bit 0	
4mA																	
4000=	0	0	0	0	1	1	1	1	1	0	1	0	0	0	0	0	

INPUT MODE 4

Using this mode, the input port will report analog values in 0-5V DC with a value of 0 - 5,000 = 0 - 5,000mV. A word is allocated for this input. The 1st byte is the low byte and the 2nd byte is the high byte.

Table 2																	
Example	Second Byte (High Byte)								First Byte (Low Byte)								
	Bit 7	Bit 6	Bit 5	Bit 4	Bit 3	Bit 2	Bit 1	Bit 0	Bit 7	Bit 6	Bit 5	Bit 4	Bit 3	Bit 2	Bit 1	Bit 0	
4000mV																	
4000=	0	0	0	0	1	1	1	1	1	0	1	0	0	0	0	0	

INPUT MODE 5

Using this mode, the input port will report analog values in 0-10V DC with a value of 0 - 10,000 = 0 - 10,000mV. A word is allocated for this input. The 1st byte is the low byte and the 2nd byte is the high byte.

Table 3																	
Example	Second Byte (High Byte)								First Byte (Low Byte)								
	Bit 7	Bit 6	Bit 5	Bit 4	Bit 3	Bit 2	Bit 1	Bit 0	Bit 7	Bit 6	Bit 5	Bit 4	Bit 3	Bit 2	Bit 1	Bit 0	
7000mV																	
7000=	0	0	0	1	1	0	1	1	0	1	0	1	1	0	0	0	

INPUT MODE 6

Using this mode, the input port will report analog values in 0-32V DC with a value of 0 - 32,000 = 0 - 32,000mV. A word is allocated for this input. The 1st byte is the low byte and the 2nd byte is the high byte.

Table 4																	
Example	Second Byte (High Byte)								First Byte (Low Byte)								
	Bit 7	Bit 6	Bit 5	Bit 4	Bit 3	Bit 2	Bit 1	Bit 0	Bit 7	Bit 6	Bit 5	Bit 4	Bit 3	Bit 2	Bit 1	Bit 0	
16000mV																	
16000=	0	0	1	1	1	1	1	0	1	0	0	0	0	0	0	0	

INPUT MODE 9

Using this mode, the input port will report analog values in Ratiometric mode with a value of 0 - 1,000 equaling 0 - 100.0%. This input will show the percentage of voltage being read compared to the source voltage. The 1st byte is the low byte and the 2nd byte is the high byte.

Table 5																	
Example	Second Byte (High Byte)								First Byte (Low Byte)								
	Bit 7	Bit 6	Bit 5	Bit 4	Bit 3	Bit 2	Bit 1	Bit 0	Bit 7	Bit 6	Bit 5	Bit 4	Bit 3	Bit 2	Bit 1	Bit 0	
10.0%																	
100=	0	0	0	0	0	0	0	0	0	1	1	0	0	1	0	0	

OUTPUT MODE 0xCh

In this mode, the output port will use PWM control with a value of 0 - 1,000 equaling 0 - 100.0% of the duty cycle. Two bytes are allocated for each of the PWM control messages with the first 12 bits being used for the value. The first byte and the first 4 bits of the second byte are put together for 12 bit control of the output.

Table 7												
Example	Second Byte (High Byte)				First Byte (Low Byte)							
	Bit 3	Bit 2	Bit 1	Bit 0	Bit 7	Bit 6	Bit 5	Bit 4	Bit 3	Bit 2	Bit 1	Bit 0
50%	0	0	0	1	1	1	1	1	0	1	0	0
500	0	0	0	1	1	1	1	1	0	1	0	0

OUTPUT MODE 0xDh

In this mode, the output port will use PWM(i) current control with a value of 0 - 4,000 equaling 0 - 4,000mA. Two bytes are allocated for each of the PWM control messages with the first 12 bits being used for the value. The first byte and the first 4 bits of the second byte are put together for 12 bit control of the output.

Table 8												
Example	Second Byte (High Byte)				First Byte (Low Byte)							
	Bit 3	Bit 2	Bit 1	Bit 0	Bit 7	Bit 6	Bit 5	Bit 4	Bit 3	Bit 2	Bit 1	Bit 0
2000mA	0	1	1	1	1	1	0	1	0	0	0	0
2000	0	1	1	1	1	1	0	1	0	0	0	0

Hardware Configuration Examples

HARDWARE CONFIGURATION MODE 0x1h (PARALLEL MODE)

This puts the output port into 'Parallel Enable' mode. Signal A and Signal B can be spliced together to form a higher amperage output of up to 8 Amps. Once enabled, the port can be toggled using Digital ON/OFF (OUTPUT MODE 0xB) or PERCENT (OUTPUT MODE 0xC) via Signal A. Signal B controls will be disabled. In this example, Parallel Mode is enabled as the hardware configuration for Port 1 using [Command 0x5Dh](#).

Table 9				
Example	First Nibble			
Parallel Enable	Bit 3	Bit 2	Bit 1	Bit 0
1	0	0	0	1

HARDWARE CONFIGURATION MODE 0x2h (H-BRIDGE MODE)

This puts the output port into 'H-Bridge Enable' mode. The output ports can be configured to H-Bridge Mode via [Command 0x5Dh](#).

DIGITAL ON/OFF MODE:

Signal A and Signal B can be used to run a directional load of up to 4 Amps forward or in reverse via the [0x51 Control Message](#). To learn more about H-Bridge direction commands, refer to the Table 10 when in [configured to Digital On/Off](#). In this example, the H-Bridge port is in Digital On/Off mode and set to Brake.

Table 10—H-Bridge Direction Example								
Example	Byte 1 (Low Byte)							
Brake	Bit 7	Bit 6	Bit 5	Bit 4	Bit 3	Bit 2	Bit 1	Bit 0
Port 1: On, On	0	0	0	0	0	1	0	1

Table 11—H-Bridge Direction Command in DIGITAL ON/OFF Mode				
	Output Channel B		Output Channel A	
	Bit 1	Bit 0	Bit 1	Bit 0
Forward Direction	0	0	0	1
Reverse Direction	0	1	0	0
Coast	0	0	0	0
Brake	0	1	0	1

PWM/PERCENT MODE:

Signal A can be used to run a directional load of up to 4 Amps forward or in reverse via [PWM Control Message](#). In this example, the H-Bridge port is being run at 50% Duty Cycle in the forward direction.

Table 12 - H-Bridge Duty Cycle Example												
Example	Second Byte (High Byte)				First Byte (Low Byte)							
50%	Bit 3	Bit 2	Bit 1	Bit 0	Bit 7	Bit 6	Bit 5	Bit 4	Bit 3	Bit 2	Bit 1	Bit 0
500	0	0	0	1	1	1	1	1	0	1	0	0

Table 13—H-Bridge Direction Command				
Example	First Nibble			
Forward Direction	Bit 3	Bit 2	Bit 1	Bit 0
1	0	0	0	1



A Murrelektronik Company